

AL-SHAJARAH

JOURNAL OF ISLAMIC THOUGHT AND CIVILIZATION
OF
THE INTERNATIONAL ISLAMIC UNIVERSITY MALAYSIA (IIUM)

SPECIAL ISSUE:
EDUCATION

2017

AL-SHAJARAH

EDITOR-IN-CHIEF

MOHAMED AJMAL ABDUL RAZAK AL-AIDRUS, IIUM, Malaysia

EDITORIAL BOARD

MOHD KAMAL HASSAN, IIUM, Malaysia

MOHAMED AJMAL ABDUL RAZAK AL-AIDRUS, IIUM, Malaysia

GUEST EDITOR:

NOORLIDE ABU KASSIM, IIUM, Malaysia

ADVISORY BOARD

HASSAN AHMED IBRAHIM, IIUM, Malaysia

KHALIQ AHMAD MOHD. ISRAIL, IIUM, Malaysia

HUNUD ABIA KADOUF, IIUM, Malaysia

MOHD ZAMBRI ZAINUDDIN, UM, Malaysia

HAMID AMINUDDIN BARRA, Mindanao State University, Philippines

ALPARSLAN ACIKGENC, Yildiz Technical University, Turkey

AMER AL-ROUBAIE, College of Business and Finance, Kingdom of Bahrain

MALIK B. BADRI, IIUM, Malaysia

OSMAN BAKAR, SOASCIS, University of Brunei, Brunei

ABDEL WAHAB EL-AFFENDI, University of Westminster, UK

KHALID MASUD, The Council of Islamic Ideology, Pakistan

HASSAN KO NAKATA, Doshisha University, Japan

SEYYED HOSSEIN NASR, The George Washington University, USA

SUN ZHENYU, Ningxia University, China

Al-Shajarah is a refereed international journal that publishes original scholarly articles in the area of Islamic thought, Islamic civilization, and Islamic science. The journal is especially interested in studies that elaborate scientific and epistemological problems encountered by Muslims in the present age, scholarly works that provide fresh and insightful Islamic responses to the intellectual and cultural challenges of the modern world. *Al-Shajarah* will also consider articles written on various religions, schools of thought and ideology and subjects that can contribute towards the formulation of an Islamic philosophy of science. Critical studies of translations of major works of major writers of the past and present and original works on the subjects of Islamic architecture and art are welcomed. Book reviews and notes are also published.

The journal is published twice a year, June-July and November-December. Manuscripts and all correspondence should be sent to the Editor-in-Chief, *Al-Shajarah*, F4 Building, IIUM Journal Publication, International Islamic University Malaysia (IIUM), No. 24, Persiaran Tuanku Syed Sirajuddin, Taman Duta, 50480 Kuala Lumpur, Malaysia. All enquiries on publications may also be e-mailed to alshajarah@iium.edu.my. For subscriptions, please address all queries to the postal or email address above.

Contributions: Submissions must be at least 5,500 words long. All submissions must be in English or Malay and be original work which has not been published anywhere else in any form (abridged or otherwise). In matters of style, *Al-Shajarah* uses the *University of Chicago Manual of Style* and follows the transliteration system shown on the inside back cover of the journal. The Editor-in-Chief reserves the right to return accepted manuscripts to the author for stylistic changes. Manuscripts must be submitted to the Editor-in-Chief in Microsoft Word. The font must be Times New Roman and its size 12. IIUM retains copyright to all published materials, but contributors may republish their articles elsewhere with due acknowledgement to *Al-Shajarah*.

©International Islamic University Malaysia
(IIUM)

ISSN 1394-6870



STRATEGIC LEADERSHIP PRACTICES AND STUDENTS' ASPIRATION OUTCOMES: WHAT WORKS IN MALAYSIAN VOCATIONAL COLLEGES?

*Hairuddin Mohd Ali
Inas Zulkipli*

Abstract

The main objective of the study is to examine and confirm the relationship among Malaysian vocational college leaders' strategic leadership practices, in-service training effectiveness and students' aspiration outcomes. Survey approach was used for data collection using an adapted five-point Likert scale instrument. A total of 500 vocational college educational leaders from sixty five (65) vocational colleges (comprised 208 males and 209 females) participated in the study. Descriptive statistics, and SEM statistical tool were used in data analysis. The study revealed that Malaysian vocational college leaders' strategic leadership practices has significant direct and indirect (through a mediator) causal effect on students' aspirations outcomes. The findings suggest that each vocational college leaders should have a unique training plan based on his/her needs. Special emphasis should be focused on inculcating the knowledge and skills of strategic leadership practices among the Malaysian vocational college leaders.

Keywords: Strategic leadership practices; in-service training effectiveness; Students' aspiration outcomes; Educational leaders; Descriptive statistics; Structural equation modeling.

INTRODUCTION

Due to the poor performance of Malaysian students in international comparative education assessments particularly in Trends in International Mathematics and Science Study (TIMSS), Programme International Student Assessment (PISA) and Progress in International Reading Literacy Study (PIRLS)¹, there was little options for the Ministry of Education Malaysia (MOEM) but to review and evaluate the achievements of the Malaysian education system and this was carried out sometime in October 2011. Indeed, the present global environment is pushing Malaysia to prepare its young people to cope with the challenges of the 21st century as well as to satisfy the infinite expectations of parents and the society towards enhancing the quality of the Malaysian education system. Consequently, the Malaysia Education Blueprint 2013-2025² was developed and implemented. The ultimate aim of the blueprint is to prepare Malaysian students to face the challenges of the 21st century by outlining six students' aspiration outcomes with regard to curricula and co-curricular activities: knowledge, thinking skills, leadership skills, bilingual proficiency, ethics and spirituality, and national identity.

In the context of the Malaysian Education Blueprint 2013-2025, students' aspirations are considered as one of the identified educational goals. Malaysian students who undergo the eleven years of compulsory schooling are expected to acquire and master all six students' aspirations highlighted in the blueprint. These aspirations were originally formulated based on the National

¹ TIMSS, PISA and PIRLS are introduced by Organization for Economic Cooperation and Development (OECD). PISA holds the assessment once per three years while TIMSS is once per every four years respectively. These assessment started in the year 2000. Malaysia first participated in the assessment in 2009. The previous top scorers were Finland, Korea, Hong Kong, Japan, China and Singapore. Malaysian achievements were considered far behind compared to its neighboring countries in South East Asia. Malaysia scored beyond 50th places in two occasions of assessments (2009 & 2012).

² Malaysia Education Blueprint 2013-2025 was developed by the MOEM as an effort for Malaysian educational excellent and sustainability. It has eleven shifts or purposes which guide the implementation of the respective education development plan.

Education Philosophy 1988 - 1999, Education Development Master Plan 2006-2010, Malaysian Tenth Development Plan 2011-2015 and the Ministry of Education Malaysia Strategic Interim Plan 2011–2020. However, the implementation of previous phases of educational reforms did not convincingly bring positive changes to the students' aspirations outcomes. Therefore, a new educational development plan i.e. Malaysia Education Blueprint 2013-2025 is developed to be implemented. Therefore, in achieving the students' aspirations outcomes, it is pertinent to focus on the execution of all strategies including upgrading the quality of in-service training programs and appoint excellent educational leaders for every school (Malaysian Education Blueprint 2013-2025).

It is clear that the achievement of the students' aspiration outcomes is an important indication of the success of Malaysia Education Blueprint 2013-2025. According to Miron et al³ students' aspirations are an important tool to evaluate the success of an educational plan. The success is also closely related and influenced by local contexts. More importantly, aspirations guide students towards future opportunities and therefore influence their future⁴. However, aspirations are a multidimensional and complex phenomenon⁵. Literature highlight a number of factors influencing students' aspirations in general; among those are strategic leadership of school leaders⁶, organizational bureaucracy in schools⁷ and teacher's in-service training effectiveness⁸.

³ G. Miron, J.N. Jones, and A.J.K Young, "Evaluation of the Kalamazoo Promise. Working Paper College of Education", Western Michigan University, 2009. Retrieved from www.wmich.edu/kpromise.

⁴ C. Muller, "The Minimum Competency Exam Requirement, Teachers' and Students' Expectations and Academic Performance". *Social Psychology of Education* 2(2) 1997, 199-216;

⁵ R. Quaglia, "Student Aspirations: A Critical Dimension in Effective Schools". *Research In Rural Education*, 6(2), 1989, 7-9;

⁶ B.J. Davies and B. Davies, "Strategic Leadership," *School Leadership and Management*, 24, no. 1 (2004): 29-38; B. Davies and B.J. Davies, "Strategic Leadership," in B. Davies, (Ed.), *The Essentials of School Leadership*, 2nd Ed. (Thousand Oaks, CA: Sage Publications, 2009).

⁷ K.B. Smith, & K.J. Meier, "Politics, Bureaucrats, and Schools". *Public Administration Review*, 54(5) 1994, 551-558.

⁸ R. Andrew, *Reflective Teaching: Effective and Research-Based Professional*

Hence, this study examines the relationship between Malaysian vocational college leaders' strategic leadership practices, in-service training effectiveness and Malaysian vocational college students' aspirations outcomes as outlined in the Malaysian Education Blueprint 2013-2025.

STRATEGIC LEADERSHIP PRACTICES, IN-SERVICE TRAINING EFFECTIVENESS AND STUDENTS' ASPIRATION OUTCOMES: FRAMING THE CAUSAL RELATIONSHIP.

Due to the presence of specific issues in the vocational education sector in Malaysia, three variables were selected for this study: vocational college leaders' strategic leadership practices, vocational college leaders' in-service training effectiveness, and vocational college students' aspiration outcomes. The study used a contemporary educational model of strategic leadership⁹ comprising organizational capabilities dimensions (strategic orientation, strategic translation, strategic alignment, strategic intervention and strategic competencies) and individual characteristics dimensions of strategic leaders (restlessness, absorptive capacity, adaptive capacity, and wisdom). Strategic orientation is defined as the ability to see the bigger picture, and understand the contextual setting of an organization¹⁰. Strategic translation is defined as ability to translate strategy into action by converting it into operational terms, and strategic alignment was defined as ability to align individuals to a future organizational state¹¹. However, Quong and Walker¹² defined strategic alignment as determining where an organization is heading and how to get there. Burgelman and Grove¹³ define strategic intervention as ability to set change in organization;

Practice. (London: Continuum International Group Leader, 2002).

⁹ Davies, B.J. and Davies, B., "Strategic Leadership,"...29-38.

¹⁰ Davies, B. and Davies, B.J., "Strategic Leadership..."

¹¹ B. Davies, "Rethinking Strategy and Strategic Leadership in Schools," *Educational Management and Administration*, no. 31 (2003): 295-312.

¹² T. Quong and A. Walker, "A Seven Principles of Strategic Leadership," *International Studies in Educational Administration*, 38, No. 1 (2010): 22-34.

¹³ R.A. Burgelman and A.S. Grove, "Strategic Dissonance," *Californian Management Review*, No. 38, (1996): 8-28.

Prahalad and Hamel¹⁴ define strategic competencies as ability to develop strategic competence, and Senge¹⁵ defined restlessness as creative tension which makes an employee unsatisfied with his/her work outcomes. Cohen and Levintha¹⁶ defined absorptive capability as ability to absorb new information while adaptive was defined as ability for change.¹⁷ Finally Davies and Davies¹⁸ defined wisdom as ability to take the right action at the right time. In general, all these sub-constructs are the characteristics and indicators of strategic educational leaders who supposedly able to realize the vocational college students' aspirations.

The second variable of this study is vocational college leaders' in-service training effectiveness. In this study it is hypothesized as a mediator. Guskey¹⁹ suggests five levels of evaluations to determine the effectiveness of training: participant's reaction, participant's learning, organizational support and change, participant's use of new knowledge and skills and students' learning outcomes. Participants' reaction is defined as initial satisfaction with the experience when learning as new knowledge and skills. Organizational support and change is defined as organization's advocacy, support, accommodation, facilitation and recognition. Guskey²⁰ also defines new skills and knowledge as degree and quality of implementation while students' learning outcomes is about cognitive, affective and psychomotor performance.

The third variable is the vocational college students' aspiration outcomes which is a dependent variable for this study. In this

¹⁴ C.K. Prahalad and G. Hamel, "The Core Competence of the Corporation," *Harvard Business Review*, No. 68, (1990): 79-93.

¹⁵ P. Senge, *The Fifth Discipline: The Art and Practice of the Learning Organization*, (New York: Currency Doubleday, 1990).

¹⁶ W.M Cohen and D.A Levinthal, "Absorptive Capacity: A New Perspective on Learning and Innovation," *Administrative Science Quarterly*, No. 35, (1990): 128-152.

¹⁷ J.A Black and K.B. Boal, "Assessing the Organizational Capacity to Change", in Heene, A. and Sanchez, R. (Eds.) *Competence-based Strategic Measurement*, (Newbury Park CA: Wiley & Sons, 1996).

¹⁸ Davies, B.J. and Davies, B., "Strategic Leadership,"... 29-38.

¹⁹ T.R Guskey, *Evaluation of Professional Development*, (Thousand Oaks, CA: Corwin Press, 2000a).

²⁰ Ibid.

context, the vocational college students' outcomes is related to the six planned students' aspiration outcomes of Malaysian Education Blueprint 2013-2025: Knowledge, Thinking Skills, Leadership Skills, Bilingual Proficiency, Ethics & Spirituality and National Identity. In general, the study hypothesized that the vocational college students' aspiration outcomes (main focus of the study outcomes) to a certain extent are influenced by the strategic leadership practices of the vocational college educational leaders. However, the influence exerted towards the students' aspirations also partly depended on the strength of the in-service training effectiveness of the vocational college educational leaders as mediating variable. Based on the aforementioned illustrations, the conceptual framework of the study is proposed as exhibited in Figure 1.

Figure 1: The Conceptual Framework of Study

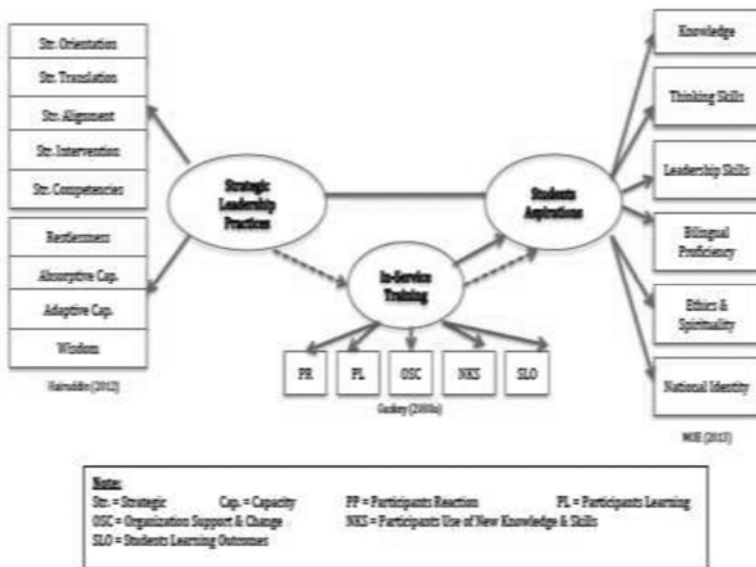

Sources: Hairuddin²¹, Guskey²² & MOEM²³

²¹ Hairuddin Mohd Ali, "The Quest for Strategic Malaysian Quality National Primary School Leaders," *International Journal of Educational Management*, 26 No. 1 (2012): 83-98.

²² T.R. Guskey, *Evaluation of Professional Development*, (Thousand Oaks, CA:

PURPOSE AND RESEARCH QUESTIONS.

The main purpose of the study is to examine the inter-relationship between strategic leaderships practices, in-service training effectiveness and students' aspiration outcomes in Malaysian vocational colleges. The detail research questions based on the conceptual framework as depicted by Figure 1 are as follows:

- (i) Is there a direct and significant relationship between strategic leadership practices and students' aspiration outcomes?
- (ii) Is there a direct and significant relationship between in-service training effectiveness and students' aspiration outcomes?
- (iii) Does in-service training effectiveness mediate the relationship between strategic leadership practices and students' aspiration outcomes?

METHODOLOGY

Population and Sampling

Sixty five (65) out of eighty (80) vocational colleges in Malaysia participated in the study as they provided a representative sample of the entire population²⁴. As suggested by Ferguson²⁵; Vockell and Asher,²⁶ a sample size of five hundred (500) would be adequate to fulfill a minimum of 95% confidence interval and 5% margin of error. The participants of this study were the Directors, Deputy Directors, Head of Departments and Head of Units of the sampled vocational colleges. After almost 2 months of fieldwork, a total of 417 (83.4%) supposedly completed questionnaires were returned to the researchers via mails. To facilitate the returning process, the respondents were provided with the self-addressed post-paid envelopes.

Corwin Press, 2000a).

²³ Ministry of Education Malaysia. *Malaysian Education Development Plan 2013-2025*, (Kuala Lumpur, 2013).

²⁴ A. Fink, *The Survey Handbook*, (London: Sage Publications, 1995).

²⁵ G.A. Ferguson, *Statistical Analysis in PhD. Education*, 5th Ed. (New York: McGraw-Hill, 1981).

²⁶ E.L Vockell and J.W. Asher, *Educational Research*, 2nd Ed. (Upper Saddle River New Jersey: Prentice-Hall, 1995).

Instrumentation

In general, the survey questionnaires employed in this study were adopted and adapted from several scholars in the respective fields of study. In Section A, the survey questionnaire seeks the respondents' demographic information such as gender, age, and academic qualification, place of work, years of service, current position, grade in current position and years of experience in current position. Section B (comprised 48 items) of the survey questionnaire is measuring vocational college leaders' strategic leadership practices where the items were developed by Hairuddin²⁷, Davies²⁸, Davies and Davies²⁹; Davies and Davies³⁰. Section C measures the vocational college leaders' in-service training effectiveness comprising 27 items based on the works of Guskey³¹. Section D comprises an array of 29 items based on the framework established by MOEM³². All survey items were translated into the National Language (Bahasa Melayu) in accordance with back-translation procedures as suggested by Brislin et al.³³. As for the validation processes, two stages of content validation and content refinement as suggested by Bourque and Clark³⁴ were successfully carried out. All items used a 5-point Likert scale anchored by 1= strongly disagree, 2=disagree, 3=neither disagree nor agree, 4=agree and 5=strongly agree.

Statistical analysis techniques

The Analysis of Moment Structures (AMOS 21.0) software was used with the Maximum Likelihood Estimation (MLE) procedure in

²⁷ Hairuddin Mohd Ali, "The Quest for Strategic Malaysian....", 83-98.

²⁸ B. Davies, *Leading the Strategically Focused School: Success and Sustainability*, (Thousand Oaks CA: Sage Publications, 2006).

²⁹ Davies, B.J. and Davies, B., "Strategic Leadership"...29-38.

³⁰ Davies, B. and Davies, B.J., "Strategic Leadership,"...

³¹ T.R. Guskey, *Evaluation of Professional...*

³² Ministry of Education Malaysia. *Malaysian Education...*

³³ R. Brislin, W. Lonner and R. Thorndike, *Cross Cultural Research Methods*, (New York: Wiley & Sons, 1973).

³⁴ L.B. Bourque and V.A. Clark, *Processing Data: The Survey Example* (Newbury Park CA: Sage Publications, 1992).

generating the estimates and analysis of covariance matrices³⁵. The hypothesized model of the study was estimated and tested using a superior technique particularly structural equation modeling (SEM). Worthington and Whittaker³⁶ and Hair et. al.³⁷ recommended that Confirmatory Factor Analysis (CFA) needs to be utilized to examine the convergent validity for each multi-dimensional construct Pursuant to that, Hair et al.³⁸ suggested to use three statistical measures: standardized factor loadings, average variance extracted (AVE), and composite reliability index (CRI). The cut-off values adopted for three statistical measures are: standardized factor loadings and AVE should be above .50 and CRI should be above .70³⁹. Once the estimates of the model were established, the study applied a set of measures suggested by Hair et.al (2010)⁴⁰ to evaluate the goodness of fit of the hypothesized model.

RESULTS

Assessment of the Measurement Models and MLE Model Estimation

The hypothesized structural model of the study is represented by 15 manifest variables from three latent variables of the study (Figure 2) namely strategic leadership practices (SL= seven sub constructs), in-service training effectiveness (IST= five sub constructs) and students' aspirations (SA= three sub constructs). AMOS 21.0 was employed in evaluating the hypothesized model of the study. The hypothesized structural model exhibited more or less acceptable fit: $\chi^2 (87) = 261.406$ and $p = .000$. Other fit indices are depicted in

³⁵ J.L. Arbuckle and W. Wothke, *Amos 4.0 User's Guide*. (Chicago: SPSS Inc., 1999).

³⁶ R.L. Worthington, and T.A. Whittaker, "Scale Development Research: A Content Analysis and Recommendations for Best Practices." *The Counseling Psychologist*, No 34. (2006): 806-838.

³⁷ J.F. Hair, W.C Black, B.J. Babin and R.E. Anderson, *Multivariate Data Analysis*, 7th Ed. (Upper Saddle River, New Jersey: Prentice-Hall, 2010).

³⁸ Ibid.

³⁹ Ibid.

⁴⁰ J.F. Hair, et al, *Multivariate Data Analysis...*

Figure 2⁴¹ below ($\chi^2=261.406$, DF=87, GFI=.904, AGFI=.868, TLI=.905, CFI=.921, RMSEA=.077, CMIN/DF=3.005). As far as SEM is concerned, the goodness of fit of the hypothesized model could be improved further by embarking certain statistical techniques.

Figure 2: The Generated Hypothesized Model of Study

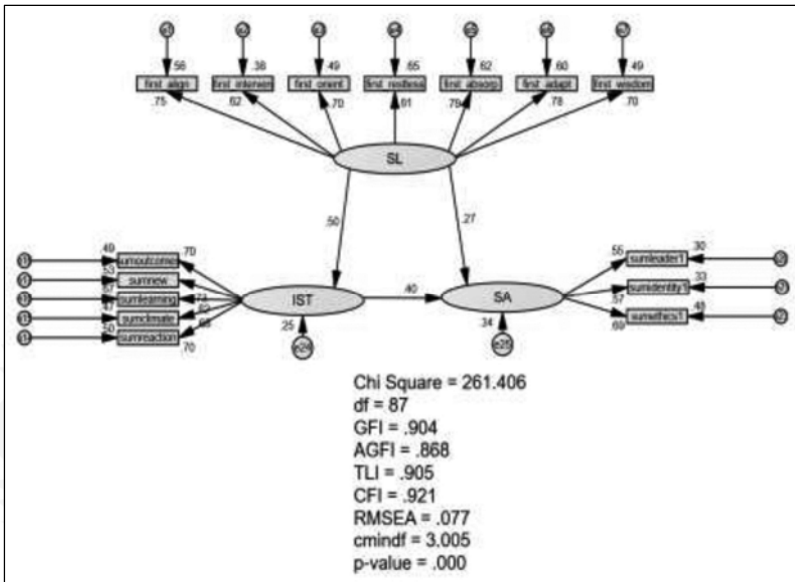

Addressing the Research Questions and Testing the Hypothesized Model.

In pursuit of better fit model, one inter-correlation between two errors was freed based on post hoc modification indices (MIs) i.e. the connection between error 1 (*first orient*) and error 3 (*first align*). It reduced the χ^2 value from 261.406 (generated hypothesized model) to 225.084 (revised model), thus improving the goodness of fit indices as depicted in Figure 3⁴². For comparison purpose, the goodness of fit indices of the re-specified model are: $\chi^2=225.084$, DF=86, GFI=.916,

⁴¹ Ibid.

⁴² Ibid.

AGFI=.883, TLI=.923, CFI=.937, RMSEA=.069, CMIN/DF=2.617, P value=.000 which in general are better than its counterpart.

Figure 3: The Revised Generated Hypothesized Model of Study

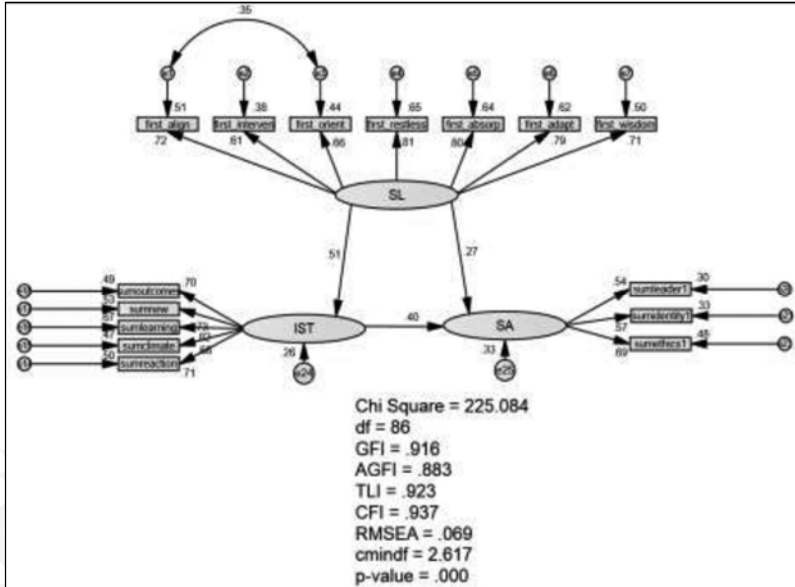

Byrne,⁴³ Tabachnick and Fidell,⁴⁴ Hair et al,⁴⁵ Martin and Bridgmon,⁴⁶ Kline,⁴⁷ and Blunch⁴⁸ recognised SEM as statistical tool for testing the hypothesis of the multivariate analysis. As exhibited by Figure 3, SL and SA were significantly and directly related at a value of .27. Therefore first research question was successfully addressed. Along with that, the study also had proved

⁴³ B.M. Byrne, *Structural Equation Modelingwith EQS and EQS/Windows: Basic Concepts, Applications and Programming* (London: Sage Publications, 2010).

⁴⁴ B.G. Tabachnick, and L.S. Fidell, *Using Multivariate Statistics*, 3rd Ed. (New York: Harper Collins Publishers, 2001).

⁴⁵ J.F Hair, et al, *Multivariate Data Analysis*...

⁴⁶ W.E. Martin, and K.D. Bridgmon, *Quantitative and Statistical Research Methods: From Hypothesis to Results*. (NY: Jossey-Bass, 2012).

⁴⁷ R.B. Kline, *Principles and Practice of Structural Equation Modeling (3rd Ed.)*. (New York: Guilford Press, 2011).

⁴⁸ J.B. Blunch, *Introduction to Structural Equation Modeling Using IBM SPSS Statistics and AMOS*. (London: Sage, 2013).

that IST and SA were also significantly and directly related with a value of .40. Hence research question two was successfully addressed. The revised model as exhibited by Figure 3 also proved that IST significantly mediated the relationship between SL ($SL > IST = .51$) and SA ($IST > SA = .27$). The revised structural model of the study evidently indicated the presence of mediating influence of IST on the relationship between SL and SA. To conclude, the study distinctively proved that all research questions were fully addressed and the revised model as exhibited by Figure 3 was valid and reliable at .05 significant level.

DISCUSSIONS

Strategic leadership practices and students' aspiration outcomes

The study provided almost perfect evidence that the Malaysian educational vocational college leaders had successfully executed at least seven characteristics of strategic leadership practices: strategic orientation, strategic alignment, strategic intervention, restlessness, absorptive capacity, adaptive capacity and wisdom, in influencing the students aspiration outcomes. These evidences are noticeably in line with Davies⁴⁹; Davies and Davies⁵⁰ and Davies⁵¹.

The study also had proved that direct influence of vocational educational leaders' strategic leadership practices on vocational college students' aspiration outcomes (magnitude of .27 regression weight standardized direct effects) is considered significant in the context of Malaysia. However, fascinatingly, the finding is contrary to the findings of Bruggencate et al.⁵², Vidoni and Grasseti⁵³, Ross and Gray⁵⁴, Ross and Gray⁵⁵, Witziers et al.⁵⁶,

⁴⁹ Davies, B.J. and Davies, B., "Strategic Leadership,"...29-38.

⁵⁰ B. Davies, *Leading the Strategically Focused...*

⁵¹ B. Davies and B.J. Davies, "Strategic Leadership,"...

⁵² G.T. Bruggencate, H. Luyten, J. Scheerens, and P. Sleegers, "Modeling the Influence of School Leaders on Student Achievement: How Can School Leaders Make a Difference?", *Educational Administration Quarterly*, 84, No. 4, (2012): 699-732.

⁵³ D. Vidoni and L. Grasseti, "The Role of School Leadership on Student Achievement: Evidence from TIMSS 2003," *The Proceedings of IRC 2003* (2008): 1-30.

Leithwood et al.⁵⁷, Hallinger and Heck⁵⁸ and Robinson et al.⁵⁹. The reasons behind it are yet to be found and therefore another study is a necessity. Therefore, the findings apparently suggests that Malaysian Vocational College Educational leaders need to be equipped with skills and knowledge of strategic leadership as this would directly improve and enhance vocational college students' aspiration outcomes.

In-service training effectiveness and students' aspiration outcomes

Guskey⁶⁰ asserted that in-service training effectiveness construct comprised five factor model. The finding of the study also strongly indicated that there was also a direct significant causal relationship between in-service training effectiveness and vocational college students' aspiration outcomes in the context of Malaysian Vocational College Education (with a magnitude of .40 standardized regression weight). Evidently the result of this study is in line with Che Mohd Zulkifli⁶¹, Thompson⁶², Shanti⁶³, Cohen and Hill⁶⁴. In regard to the

⁵⁴ J. Ross and P. Gray, "Transformational Leadership and Teacher Commitment to Organizational Values: The Mediating Effect of Collective Teacher Efficacy," *School Effectiveness and School Improvement*, 17, No. 2 (2006): 179-199.

⁵⁵ J. Ross and P. Gray, "School Leadership and Student Achievement: The Mediating Effect of Teacher Beliefs", *Canadian Journal of Education*, 29, No. 3 (2006): 798-822.

⁵⁶ B. Witziers, R.J. Bosker and M.L. Kruger, "Educational Leadership and Student Achievement: The Elusive Search for an Association", *Educational Administration Quarterly*, 39, No. 3, (2003): 398-425.

⁵⁷ K.A. Leithwood, D. Jantzi, and R. Steinbach, *Changing Leadership for Changing Times* (Buckingham, UK: Open University Press, 1999).

⁵⁸ P. Hallinger and R. Heck, "Reassessing the Principal's Role in School Effectiveness: A Review of Empirical Research 1980-1995," *Educational Administration Quarterly*, 32, No. 1, (1996): 5-44.

⁵⁹ V.M.J Robinson, C. Lloyd and K.J Rowe, "The Impact of Leadership on Student Outcomes: An Analysis of the Differential Effects of Leadership Type", *Educational Administration Quarterly*, 44, No. 5 (2008): 635-674.

⁶⁰ T.R Guskey, *Evaluation of Professional...*

⁶¹ Che Mohd Zulkifli, "The Need for In-Service Training for Teachers and its Effectiveness in School," *International Journal for Innovation Education and Research*, 2, No. 11 (2014): 1-9.

⁶² C.L Thompson, *Improving Student Performance Through Professional*

finding of this study, Garet⁶⁵ revealed that mathematics teachers' involvement in the in-service training programs are pedagogically prepared to implement change in teaching practice, improve in knowledge and teaching skills. The above findings were also supported by Hanushek⁶⁶ Andrew⁶⁷, Borich⁶⁸; Clotfelter et al.,⁶⁹; Guskey⁷⁰ and Guskey⁷¹, Hawley and Valli⁷², Joyce and Showers⁷³, Fullan, Hill and Crevola,⁷⁴ McCutchen et al.⁷⁵ and Angrist and

Development for Teachers, (NC: Education Research Council, 2003).

⁶³ Shanti D/O Rangharan, "Peranan dan Tanggungjawab Guru Dalam Meningkatkan Professionalisme Perguruan Kariah Pencapaian Pendidikan Cemerlang," (Unpublished Master's Thesis, Universiti Kebangsaan Malaysia, 1998).

⁶⁴ D.K. Cohen and H.C. Hill, *Learning Policy: When State Education Reform Works*, (New Haven: Yale University Press, 2001).

⁶⁵ M.S. Garet, "What Makes Professional Development Effective? Results from a National Sample of Teachers", *American Education Research Journal*, 38, No. 4 (2001): 915-945.

⁶⁶ E.A. Hanushek, "The Economics of Schooling: Production and Efficiency in Public Schools", *Journal of Economic Literature*, 24, No. 3, (1986): 41-77.

⁶⁷ R. Andrew, *Reflective Teaching: Effective and Research-Based Professional Practice*, (London: Continuum International Group Leader, 2002).

⁶⁸ G.D. Borich, *Effective Teaching Methods*, 5th Ed., (New Jersey: Prentice-Hall, 2003).

⁶⁹ C.T. Clotfelter, F.L. Helen, and L.V. Jacob, *Teacher Credentials and Student Achievement in High School: A Cross-subject Analysis with Student Fixed Effects*, Working Paper#11, (Washington DC: CALDER, 2007).

⁷⁰ T. Guskey, "Professional Development in Education: In Search of the Optimal Mix", In *Professional Development in Education: New Paradigms and Practices*, (T. Guskey and M. Huberman) (Eds.) (New York: Teachers College Press, 1995): 114-132.

⁷¹ T. Guskey, "Does it Make a Difference? Evaluating a Professional Development," *Educational Leadership*, 59, No. 6 (2000): 45-51.

⁷² W. Hawley and L. Valli, The Essentials of Effective Professional Development: A New Consensus. In *Teaching as the Learning Profession : Handbook of Policy and Practice*, Darling-Hammond, L. and Sykes, G (Eds). (San Francisco: Jossey-Bass, 1999).

⁷³ B. Joyce and B. Showers, *Student Achievement Through Staff Development*, 3rd Ed., (Alexandria: ASCD, 2002).

⁷⁴ M. Fullan, P. Hill and C. Crevola, *Breakthrough*, (New York: Corwin Press, 2006).

⁷⁵ D. McCutchen, R.D. Abbott, L.B. Green, S.N. Beretvas, S. Cox, N.S. Potter, T. Quiroga and A.L. Gray, "Beginning Literacy: Links Among Teacher Knowledge, Teacher Practice, and Student Learning", *Journal of Learning Disabilities*, No. 35

Lavy.⁷⁶ Therefore, this study might strongly suggest that the decision and policy makers need to embark on in-service training effectiveness as it increases the students' aspiration outcomes.

The influence of the mediating variable: in-service training effectiveness.

The finding from the study proved there was quite a significant indirect relationship between strategic leadership practices of vocational college educational leaders and the vocational college students' aspiration outcomes. To certain extent, in-service training effectiveness proved played its role as a mediating variable (magnitude of .51*.40 standardized regression weight). Therefore, in Malaysian context of vocational education sector, the finding suggests that in-service training effectiveness factor of the educational leaders somewhat displayed its influence in enhancing the vocational college students' aspiration outcomes. The finding complemented Cheng and Tsui⁷⁷ that expertise development of teachers indirectly influenced the students' achievements and aspirations.

IMPLICATIONS

There are two perspectives of implications to be discussed particularly theoretical and practical, and Islamic aspects. Apparently the study had confirmed a seven-factor model of strategic leadership practices in the context of Malaysian vocational college leaders as compared to the nine-factor model for the United Kingdom⁷⁸. Nevertheless, the five-factor model of in-service training effectiveness from this study in some way supported the importance of continuous professional development (CPD) for school leaders as

(2002): 69-86.

⁷⁶ J.D. Angrist and V. Lavy, "Does Teacher Training Affect Pupil Learning? Evidence from Matched Comparisons in Jerusalem Public Schools", *Journal of Labour Economics*, 19, No. 2 (2001): 343-369.

⁷⁷ Y.C. Cheng and K.T. Tsui, "Total Teacher Effectiveness: New Conception and Improvement", *International Journal of Educational Management*, No. 6 (1996): 7-17.

⁷⁸ B. Davies and B.J. Davies, "Strategic Leadership,"...

been emphasized by Che Mohd Zulkifli⁷⁹, Clotfelter et al.⁸⁰, Fullan, Hill and Crevola⁸¹, Andrew⁸², Joyce and Showers⁸³, Garet⁸⁴, Angrist and Lavy⁸⁵, Hawley and Valli⁸⁶, Shanti⁸⁷, Guskey⁸⁸, and Hanushek⁸⁹. In Malaysian context, the findings from the study would bring some insight to what extent does strategic leadership are practiced among the vocational educational leaders and also, to what extent in-service training effectiveness plays its roles in influencing the roles of strategic leadership on students' aspiration outcomes.

Al-Mawardi,⁹⁰ Basbous⁹¹, and Al-Wakil⁹² used the word Imamah to describe leadership in the context of "guarding of the religion and life". However, Ali stressed that leadership in Islam⁹³ is

⁷⁹ Che Mohd Zulkifli, "The Need for In-Service Training...1-9.

⁸⁰ Clotfelter, C.T., Helen, F.L. and Jacob, L.V., *Teacher Credentials and Student Achievement in High School: A Cross -subject Analysis with Student Fixed Effects*, Working Paper#11, (Washington DC: CALDER, 2007).

⁸¹ Fullan, M., Hill, P. and Crevola, C., *Breakthrough*, (New York: Corwin Press, 2006).

⁸² Andrew, R., *Reflective Teaching: Effective and Research-Based Professional Practice*, (London: Continuum International Group Leader, 2002).

⁸³ Joyce, B. and Showers, B., *Student Achievement Through Staff Development*, 3rd Ed., (Alexandria: ASCD, 2002).

⁸⁴ Garet, M.S., "What Makes Professional Development Effective? Results from a National Sample of Teachers", *American Education Research Journal*, 38, No. 4 (2001): 915-945.

⁸⁵ Angrist, J.D. and Lavy, V., "Does Teacher Training Affect Pupil Learning? Evidence from Matched Comparisons in Jerusalem Public Schools", *Journal of Labour Economics*, 19, No. 2 (2001): 343-369.

⁸⁶ Hawley, W. and Valli, L., The Essentials of Effective Professional Development: A New Consensus. In *Teaching as the Learning Profession : Handbook of Policy and Practice*, Darling-Hammond, L. and Sykes, G (Eds). (San Francisco: Jossey-Bass, 1999).

⁸⁷ Shanti D/O Rangharan, *Peranan dan Tanggungjawab Guru...*

⁸⁸ T. Guskey, "Does it Make a Difference...45-51.

⁸⁹ E.A. Hanushek, "The Economics of Schooling: Production and Efficiency in Public Schools", *Journal of Economic Literature*, 24, No. 3, (1986): 41-77.

⁹⁰ Al-Mawardi, *Al-Ahkam Al-Sultaniyah*, (Beirut: Dar al-Kutub al-Ilmiyah, 1983).

⁹¹ M.A. Basbous, *Fan al-Qiyadah fi al-Islam*, Jordan: Maktabat Al-Manar, 1988), 47

⁹² M.S. Al-Wakil, *Al-Qiyadah wa Al-Jondiyah fi Al-Islam*, (Egypt: al-Wafa Littiba" a wa al-Nashr, 1988), 22.

⁹³ A.Y. Ali, *The Holy Qur'an, English Translation of the Meanings and*

part of worshipping Allah (ﷻ). It is not only aimed to serve the members of the organization, but the most important goal is to guide people towards what is the best in this world and the Hereafter. Therefore, if strategic leadership practices of educational leaders and in-service training effectiveness had significant and directly related with the student aspiration outcomes, then we are very certain that good intention (or niat) together with all universal Islamic values could also be internalized and consequently influence the student aspiration outcomes in the context of Malaysian vocational college education. All strategic leadership and in-service training effectiveness, if well blended with the Islamic values, would positively affect the student aspiration outcomes.

Strategic leadership does not only deal with an organizational context, but also must be related to the Islamic religion's objectives specifically responsibility and 'amanah'. Accomplishment of the responsibilities is mandatory or 'wajib'. This is greatly important for the vocational educational leaders in the context of Malaysia.

Another pertinent implication is about the need of a visionary leaders due to the strategic actions that they supposed to undertake in future. A Muslim strategic leader must be a forward-looking servant with a vision. The clear vision guides him towards the achievement of the objectives by following the right way and method. Strategic leaders have to transform this clear vision to the members of the organization. Allah (s.w.t) asked the Prophet (ﷺ) and his companions to be patient and do not go against their oppressors because the final vision had yet to be achieved. Allah (s.w.t) said in the Qur'an, "Hast thou not turned thy thought to those who were told to hold back their hands (from fight) but establish regular prayers and spend in regular Zakah..."⁹⁴

Serving the ummah is one of the primary roles of a Muslim strategic leader. A strategic educational leadership practice in this context is not about a matter of privilege or position but rather, an enormous responsibility. Educational leaders need to feel that they are the servants of their followers. This feeling will help strategic

Commentary. (Al-Madinah al-Munawwarah: King Fahd Complex for the Printing of the Holy Qur'an, 1985).

⁹⁴ Al Qur'an 4: 77.

leaders to make great efforts towards protecting the members of the organization. The Prophet (ﷺ) said, “A ruler who has been entrusted with the affairs of the Muslims but makes no endeavor (for the material and moral upliftment) and is not sincerely concerned (for their welfare) will not enter Paradise along with them.”⁹⁵

A Muslim strategic leader is concerned about his followers' well-being. Allah (s.w.t) said in the Qur'an, “And We made them leaders, guiding (men) by Our command, and We inspired them to do good deeds, to establish regular prayers and to give Zakah and they constantly served Us (and Us only).”⁹⁶ Importantly, a Muslim leader's job is not only to serve and guide people but to bring changes for the betterment of their lives. By successfully influencing the followers, strategic leaders will be able to exhibit their spirit, knowledge and experience to everybody in the organization. However, this will not be achieved unless strategic leaders portray themselves as good models for their followers. An excellent example was that the Prophet (ﷺ) was very successful in influencing people and guiding them to the new religion - beginning with his wife Khadija (r.a), his close companion Abu Bakr al-Siddiq (r.a) and later, all other companions.⁹⁷

A strategic educational leader needs to enhance the potentials and capabilities of all organizational members spiritually, mentally, intellectually, psychologically, socially and professionally. The Prophet (ﷺ) used to teach his companions in different ways, especially when somebody was given a position involving leadership. As an example, when Prophet Muhammad (ﷺ) appointed Ali Ibn Abi Talib (r.a.) as a judge in Yemen, he was a bit concerned due to Ali Ibn Abi Talib (r.a.) inexperience as a law man. In supporting this, Ali (r.a.) said: “the Prophet (ﷺ) sent me to Yemen as a judge. I said, Oh! Messenger of Allah! I am a youth, how could you send me to a people who are far advanced in years than me. The Prophet prayed for me, and said: “If two adversaries approach you; (for fair judgement) and you hear the claim of one, do not judge until you

⁹⁵ *Muslim*, n.d. Vol. 1, ch. 44, hadith No. 264, 82.

⁹⁶ Al Qur'an 21: 73.

⁹⁷ M. Abdul-Wahhab, *Mokhtasar Sirat Al-Rasoul Sallah Allahu Alaihi wa Sallam*, (Damascus: Dar al-Fayha, 1997), 97.

have heard from the other, for this is to decide the case.”⁹⁸ It is clear here that Prophet Muhammad (ﷺ) had taught Ali (r.a.) the central and most general rule to be practised by a judge. Muslim strategic leaders, therefore, should follow such examples and train their followers how to accomplish the assigned jobs. By doing so, members will be more confident and professional in handling their duties.

FUTURE RESEARCH WORKS AND CONCLUSION.

In term of sampling, future studies should consider different administrative levels as a separate sample groups and a multi-group. Also ensure serious consideration of merging the Islamic values constructs with the present constructs⁹⁹ of strategic educational leadership. If there is a need to develop the strategic leadership practices inventory for the Malaysian vocational and school leaders, the leaders from all school types (e.g. national schools, national-type schools, and religious schools) should be considered as participants in the nation-wide study. Thus, the goal to enrich the indigenous strategic educational leadership practices body of knowledge for Malaysian school leaders shall be realized indeed.

⁹⁸ Al-Baihaqi Vol.10, *Kitab A'dab al-Qadi*, 86.

⁹⁹ R. Fontaine and Khaliq Ahmad, *Strategic Management from an Islamic Perspective: Text and Cases*. (Singapore: John Wiley and sons, 2013).

TRANSLITERATION TABLE

CONSONANTS

Ar=Arabic, Pr=Persian, OT=Ottoman Turkish, Ur=Urdu

Ar	Pr	OT	UR	Ar	Pr	OT	UR	Ar	Pr	OT	UR	
ء	'	'	'	ز	z	z	z	گ	—	g	g	g
ب	b	b	b	ژ	—	—	ʀ	ل	l	l	l	l
پ	p	p	p	ژ	—	zh	j	م	m	m	m	m
ت	t	t	t	س	s	s	s	ن	n	n	n	n
ث	—	—	ṭ	ش	sh	sh	ʃ	ه	h	h	h'	h'
ث	th	th	th	ص	ṣ	ṣ	ʃ	و	w	v/u	v	v/u
ج	j	j	c	ض	ḏ	ḏ	ʒ	ی	y	y	y	y
چ	—	ch	çh	ط	ṭ	ṭ	ṭ	ة	-ah	—	—	-a ²
ح	ḥ	ḥ	ḥ	ظ	ẓ	ẓ	ẓ	ال	al ³	—	—	—
خ	kh	kh	kh	ع	'	'	'	—	—	—	—	—
د	d	d	d	غ	gh	gh	ğh	—	—	—	—	—
ڈ	—	—	d	ف	f	f	f	—	—	—	—	—
ذ	dh	dh	dh	ق	q	q	k	—	—	—	—	—
ر	r	r	r	ك	k	k/g	k/ñ	—	—	—	—	—

¹ – when not final
² – at in construct state
³ – (article) al - or l-

VOWELS

	Arabic and Persian	Urdu	Ottoman Turkish
Long	ا	ā	ā
	آ	Ā	—
	و	ū	ū
	ي	ī	ī
Doubled	ي	īy (final form ī)	īy (final form ī)
	و	uww (final form ū) uvv (for Persian)	uvv
Diphthongs	و	au or aw	ev
	ی	ai or ay	ey
Short	ا	a	a or e
	ا	u	u or ū
	ی	i	o or ö
	ی	i	i

URDU ASPIRATED SOUNDS

For aspirated sounds not used in Arabic, Persian, and Turkish add h after the letter and underline both the letters e.g. جھ jh گھ gh

For Ottoman Turkish, modern Turkish orthography may be used.

AL-SHAJARAH

Special Issue

Contents

THE CURRICULUM OF ISLAMIC STUDIES AND ISLAMIC STUDIES EDUCATION PROGRAMS IN MEETING THE CHALLENGES OF GLOBALIZATION: A CASE STUDY OF SELECTED MALAYSIAN UNIVERSITIES <i>Rosnani Hashim</i>	1
EXPLORING REPEATING STUDENTS' FEELINGS AND ATTITUDES TOWARDS LEARNING ESL WRITING <i>Ismail Sheikh Ahmad, Rosnani Kassim, Ainol Madziah Zubairi</i>	33
ISLAMIZATION OF KNOWLEDGE IN THE CURRICULUM AMONG ACADEMICS AT THE INTERNATIONAL ISLAMIC UNIVERSITY MALAYSIA: A STRUCTURAL EQUATION MODELING (SEM) APPROACH <i>Nik Ahmad Hisham Ismail, Mustafa Teke, Faizah Idrus</i>	51
STRATEGIC LEADERSHIP PRACTICES AND STUDENTS' ASPIRATION OUTCOMES: WHAT WORKS IN MALAYSIAN VOCATIONAL COLLEGES? <i>Hairuddin Mohd Ali, Inas Zulkipli</i>	77
AL-QIYAM AL-ISLAMIYYAH AND ITS IMPACT ON MUSLIM COMMUNITIES' STABILITY <i>Ismail Hassanein Ahmed Mohamed, Faizah Idrus, Fuad Mahmoud Rawash</i>	97
ALLAH WANTS YOU TO BE RICH: FOUNDATIONS OF MUSLIM CAREER DEVELOPMENT IN AL-GHAZĀLĪ'S IḤYĀ' 'ULŪM AL-DĪN <i>Ssekamanya Siraje Abdallah, Mastura Badzis, Khamsiah Ismail</i>	131
HIERARCHY OF 7M-TEACHER-LEADER FROM ISLAMIC PERSPECTIVES <i>Mohamad Johdi Salleh, Abdul Karnaen</i>	157
FRAMEWORK FOR INCULCATING ISLAMIC VALUES THROUGH PROBLEM SOLVING IN MATHEMATICS AND LESSON STUDY APPROACH <i>Madihah Khalid</i>	197
COMMODIFICATION OF KNOWLEDGE IN HIGHER EDUCATION: WHERE IS THE SEAT OF MAQASID AL-SHARI'AH AND ISLAMISATION? <i>Azam Othman, Suhailah Hussien, Suzana Suhailawaty Md Sidek, Ahmad Faizuddin</i>	219
INSTITUTIONALIZING EDUCATION AND THE CULTURE OF LEARNING IN MEDIEVAL ISLAM: THE AYYŪBIDS (569/966 AH) (1174/1263 AD) LEARNING PRACTICES IN EGYPT AS A CASE STUDY <i>Merah Souad, Tahraoui Ramdane</i>	245
MEDIEVAL MUSLIM SCHOLARS: TEACHERS, MISSIONARIES AND THEORETICIANS, QĀDI AL-NU'MĀN AS A CASE STUDY <i>Tahraoui Ramdane, Merah Souad</i>	277
ENGLISH FOR RELIGIOUS PURPOSES: AN INQUIRY-BASED PEDAGOGY FOR MUSLIM ESL LEARNERS <i>Abdul Shakour Preece</i>	307
THE CONCEPT OF MURABBI IN MUSLIM EDUCATION WITH REFERENCE TO SELECTED TEACHING METHODS OF THE PROPHET MUHAMMAD (ﷺ) <i>Kamal J. I Badrasawi, Abdul Shakour Preece, Che Noraini Hashim, Nik Md Saiful Azizi</i>	327
NOTES ON CONTRIBUTORS	359

WoS-Indexed under *Arts & Humanities Citation Index, Current Contents/Arts and Humanities* and **Scopus**

ISSN 1394-6870



9 771394 687009