

Artificial Intelligence a new paradigm for distributed sensor networks on the Internet of Things: A Review

Ahmad Anwar Zainuddin^{1*}, Muhammad Ammar Zakirudin², Ahmad Syameer Syafiq Zulkefli³, Ahmad Muhsin Mazli⁴, Muhammad Al Syahmi Mohd Wardi⁵, Muhammad Nazmi Fazail⁶, Muhammad Irfan Zaki Mohd Razali⁷, Muhammad Haziq Yusof⁸

^{1,6,7,8}Dept. Computer Science, International Islamic University Malaysia. Kuala Lumpur, Malaysia,
^{2,3,4,5}Dept. Information Technology, International Islamic University Malaysia. Kuala Lumpur, Malaysia

*Corresponding author: anwarzain@iiu.edu.my

(Received: 26th August 2023; Accepted: 1st December 2023; Published on-line: 28th January 2024)

Abstract— The confluence of Artificial Intelligence (AI) with the Internet of Things (IoT) has created new opportunities for distributed sensor networks in a variety of sectors. The potential of AI as a new paradigm for distributed sensor networks in the IoT is investigated in this review article, with an emphasis on the convergence of architecture, methodologies, platforms, sensors, devices, energy approaches, communication and networking, and applications. An analysis was conducted to examine the existing research in this field using a comprehensive literature review, revealing notable advancements, and indicating the need for further investigation. Furthermore, Moreover, suggestions and ideas are presented regarding potential innovation within the sector, with a particular emphasis on the imperative for further research and development. Our findings highlight AIoT's transformational ability in allowing more efficient and intelligent sensor networks, with implications for smart homes, healthcare, environmental monitoring, and industrial automation. The potential for harnessing the power of AI holds the key to unlocking novel opportunities and addressing the challenges inherent in dispersed sensor networks within the realm of the Internet of Things (IoT). This research advances our understanding of AIoT convergence and lays the groundwork for future breakthroughs in this interesting topic.

Keywords— Artificial Intelligence, Internet of Things, AIoT (combination of AI and IoT), Distributed Sensor Networks, Sensor Intelligence, Machine Learning, Deep Learning, Edge Computing, Energy Efficiency, Communication and Networking, Applications of AIoT, IoT Technologies, Smart Sensors, Data Security and Privacy

I. INTRODUCTION

This paper delves into the transformative potential of Artificial Intelligence (AI) as a new paradigm for distributed sensor networks within the Internet of Things (IoT). The first section outlines the fundamental concepts of AI and IoT, paving the way for the exploration of their convergence in the context of AIoT. Section 2 summarizes the supporting literature that provides insights into the current state and advancements in AIoT. In Section 3, we present the methodology adopted for conducting the literature review. Section 4 offers innovative recommendations to further advance the implementation of AI-based sensors in IoT systems. Finally, in Section 5, we draw conclusions from our research.

A. The convergence of architecture, techniques, and platforms for AIoT

The convergence of the architecture, methods, and platforms for artificially intelligent of things (AIoT) is covered in this section. With the increasing number of

wireless sensor networks and the escalating volume of sensor data, the need for effective communication becomes increasingly important. For large-scale data processing methods like deep learning, however, this increase in connectivity poses a significant challenge because the server must manage the processing of the obtained data[1]. This issue can be effectively solved by implementing a distributed deep-learning processing approach that makes use of edge computing and mobile terminal [1]. This method proposes a parallel processing approach for convolutional layers using a number of mobile terminals, reducing server demand and enabling efficient data processing[1].

A deeper comprehension of the convergence between architecture, methodologies, and platforms for AIoT presents an opportunity to enhance the optimization of communication and data processing capabilities within distributed sensor networks operating in the Internet of Things (IoT). The collection, analysis, and use of sensor data could be revolutionised by this convergence, opening the door to cutting-edge AIoT applications and breakthroughs. Figure 1 shows types of services that are used in Cloud

<https://doi.org/10.31436/ijgcc.v10i1.414>

Computing. Moreover, cloud computing also contributes. Software as a Service (SaaS), Platform as a Service (PaaS), and Infrastructure as a Service (IaaS) are three well-known service types that are used in cloud computing [2]. For AIoT applications, these service models offer crucial tools and resources. In the context of AIoT, cloud computing can effectively handle advanced AI models and large-scale data processing requirements. One significant advantage is that the cloud can receive data from Internet of Things (IoT) devices and apply potent AI algorithms for analysis. By utilizing cloud-based AI models, large datasets can be processed efficiently, benefiting from the dispersed computing resources offered by the cloud. This approach enables organizations to leverage sophisticated analytics and gain valuable insights from their data-intensive AI-driven analysis tasks. Furthermore, cloud computing's service models offer additional advantages. In the SaaS model, software and related data can be distributed by a cloud service provider, allowing users to access them conveniently through web browsers. PaaS provides consumers with a collection of software tools that are tailored to carry out specific activities related to AIoT. Additionally, IaaS grants consumers access to storage and virtual computers, enhancing their ability to leverage cloud resources effectively. By incorporating cloud computing into the convergence of architecture, techniques, and platforms for AIoT, organizations can take full advantage of its service models to support data-intensive activities and enable AI-driven analysis. This integration allows for scalable and efficient processing of AI algorithms, making cloud computing a valuable component within the AIoT ecosystem.

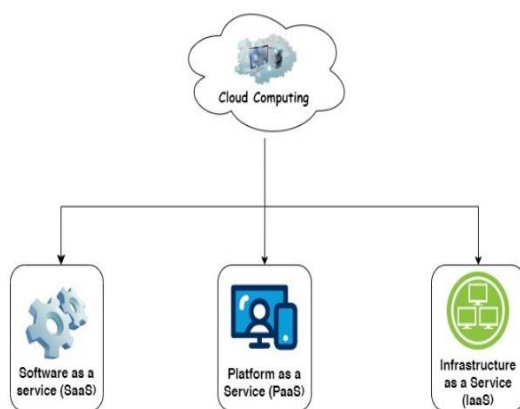

Fig. 1 Types of services that are used in Cloud Computing

Several models for IoT systems have been offered while thinking about the architecture of AIoT. These models include the machine-to-machine (M2M) architecture, the web of things architecture, the EPCglobal architecture based on sensor networks, and the autonomous architecture. Among these, M2M architecture, which includes components of EPCglobal and Wireless Sensor Network (WSN), is frequently employed in IoT applications[3]. Figure 2 indicates the authentication model in wireless sensor network. The Internet of Medical Things (IoMT) is a focused application of IoT technology within the framework of the medical industry[3]. It adheres to the standard three-tier IoT application architecture, which is made up of the perception layer, network layer, and transmission layer[3]. However, the convergence of architecture made possible by the incorporation of AI approaches enables improved data processing, forecasting, and real-time decision-making inside distributed sensor networks. By harnessing the potential of artificial intelligence (AI) within the Internet of Things (IoT), a transformative paradigm for distributed sensor networks can be established. AIoT developments in architecture, methods, and platforms lead to improvements in data processing, wise decision-making, and resource-effective resource management. It makes it possible for intelligent systems to respond to changing environments and adapt to them, creating new opportunities for a variety of applications outside the medical industry.

B. The convergence of sensors, devices, and energy approaches for AIoT

A key component of the Artificial Intelligence of Things (AIoT) paradigm is the convergence of sensors, devices, and energy strategies. In this section, we thoroughly investigate the significance of this convergence and its impact on the advancement of AIoT systems.

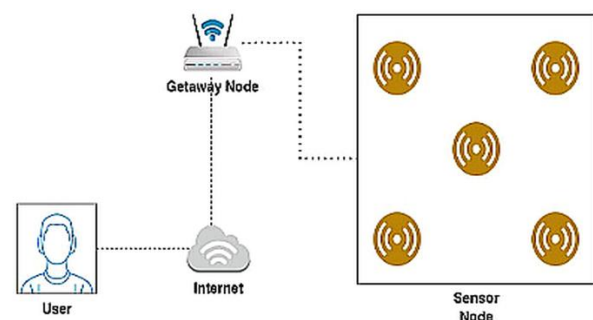

Fig. 2 Authentication model in wireless sensor network.

Wireless sensor networks (WSNs) and the Internet of Things (IoTs) have created crucial links between the physical and digital worlds, making it possible to observe the physical world at a reasonable cost. As the information carrier in IoT systems and WSNs, sensory data is essential. In these systems, sensory data processing normally happens in three stages[4].

i. Sensory Data Acquisition: In this preliminary stage, sensing apparatuses collect sensory information from the seen physical environment. The physical world is always changing, but this process can be viewed as distinct[4].

ii. Sensory Data Collection: In the second phase, the network is used to send a sink node the raw sensor data collected from each sensor node. In order to facilitate data transmission between an IoT system or WSN and the cyber world, such as cloud platforms or data centers, the sink node acts as a particular connection between them[4].

iii. Computing with Sensory Data: After the sensory data has entered the cyber realm in the second phase, additional computations are carried out in accordance with the needs of the applications and users. These calculations might involve information discovery, numerical analysis, and other pertinent processes[4].

All of the three phases above are necessary and fundamental for any application of IoT systems and WSNs[4].

In an AIoT environment, sensors act as the main conduit between the analogue and digital worlds. They gather and send data from the environment, allowing for monitoring and analysis in real-time. Application such as smart cities, healthcare, agriculture, and industrial automation is thereby the contribution of the development in sensor technology, such as miniaturization, precision increment, and increasing numbers of connectivity. This study focuses on exploring significant advancements in sensor technology and their implications on the Internet of Things (IoT).

Furthermore, in the IoT ecosystem, devices or "things" include a diverse set of interconnected entities such as smart devices, actuators, embedded systems, and wearables. Within the (AIoT) architecture, these devices serve as data sources, processing units, and decision-making nodes[5]. The integration of devices with AI technology allows intelligent and autonomous functions, increasing the efficiency and responsiveness of AIoT systems. This examination delves into the integration of AI capabilities into devices and the resultant implications for the deployments of AIoT (Artificial Intelligence of Things) systems.

Energy techniques are crucial for AIoT system sustainability and lifespan. With the growth of connected devices and the requirement for continuous operation, energy efficiency, and control are becoming increasingly important. This includes creating novel energy-collecting

techniques, optimizing power use, and investigating renewable energy sources to power AIoT devices and networks. This investigation aims to explore the latest trends and breakthroughs in energy-efficient methods for AIoT, with a particular focus on the importance of energy-aware design and resource optimization.

The convergence of sensors, devices, and energy techniques is the cornerstone for AIoT system efficiency and scalability. Insights into the growing environment of AIoT deployments can be obtained by evaluating developments in sensor technology, the integration of AI capabilities into devices, and energy issues. Subsequently, a more in-depth exploration will be undertaken to examine the convergence of communication and networking, along with the applications of AIoT. This comprehensive analysis aims to provide a thorough understanding of this disruptive paradigm.

C. *The Convergence of Communication and Networking for AIoT*

The growth and viability of Artificial Intelligence of Things (AIoT) paradigm depend critically on the convergence of communication and networking. In this part, The relevance of this convergence and its potential impact on the seamless integration of AI technologies into IoT systems will be thoroughly examined.

The foundation for tying together numerous devices and sensors in an AIoT ecosystem is communication and networking infrastructure. Real-time decision-making, data analytics, and remote control are made possible in AIoT applications by reliable and effective data transfer combined with low latency and high bandwidth connectivity[5]. This exploration will delve into the facilitation of the fusion between AI and IoT, driven by advancements in communication protocols, network designs, and emerging technologies such as 5G, edge computing, and fog computing.

AIoT systems are continuously improved by the combination of AI with communication and networking technology. For example, machine learning algorithms may be implemented at IoT gateways or at the network edge to provide real-time data processing, local decision-making, and a decreased dependency on cloud resources. Plus, it also improves scalability, dependability, and energy efficiency which are contributed by great resource allocation, adaptive routing, and self-optimizing networks[6]. This investigation aims to examine the synergistic relationship between AI and communication/networking, highlighting the transformative possibilities that arise from this powerful combination.

Additionally, the convergence of networking and communication for AIoT creates crucial questions about data security, privacy, and interoperability. Having smooth

<https://doi.org/10.31436/ijpcc.v10i1.414>

and secure connectivity becomes essential as more and more platforms, devices, and sensors are used in AIoT deployments. In order to allow safe and interoperable AIoT networks, This examination will focus on the challenges and opportunities associated with data security, authentication, encryption, and standardization within the context of AIoT.

Realizing the full potential of AIoT systems requires the convergence of networking and communication. Insights into the evolving landscape of AIoT deployments are gained through a comprehensive examination of advancements in communication protocols, network designs, and the integration of AI technology[7]. To gain a comprehensive understanding of the revolutionary impact of AIoT on dispersed sensor networks within the Internet of Things, further investigation will be conducted to explore the convergence of applications in the AIoT context. Subsequently, this study will provide recommendations for innovation and future research endeavors.

D. The convergence of applications for AIoT

i. Environmental, smart agriculture, and AIoT

Sustainable development is the focus of the interconnected domains of nature, smart agriculture, and IoT. AIoT is used in smart agriculture to improve pest management, monitor environmental conditions, and optimize farming practices. Farmers may make educated decisions, avoid resource waste, and lessen environmental impact by integrating sensors and data analytics[8]. AIoT-based systems provide preemptive interventions and real-time monitoring, enhancing agricultural output and sustainability. This fusion of technologies offers innovative ways to protect the environment, improve agricultural productivity, and guarantee food security. Some examples of application for this is Forest control systems which have been developed as a result of IoT and big data analytics. For instance, a peatland forest monitoring system driven by the Internet of Things uses solar-powered equipment to monitor environmental conditions and prevent calamities.

The detection of pests and illnesses in forests has also been done using high-resolution satellite photography. By offering insightful information and effective pest control and deforestation early warning systems, these technologies improve sustainable forest management[8]. Another example is Fish farming and soilless plant culture. Both are combined in aquaponics. Figure 3 exhibits the standard aquaponics plantation which are incorporating IoT technology to monitor and regulate water quality factors that are essential for the well-being of fish and plants. Monitoring conditions including water level, temperature, salinity, pH, and sunlight is part of this. Farmers may improve conditions, automate control systems, and increase aquaponics productivity by using IoT[8]. IoT solutions enable real-time monitoring, data-driven decision-making,

and automated control, which boosts aquaponics farming's productivity and sustainability.

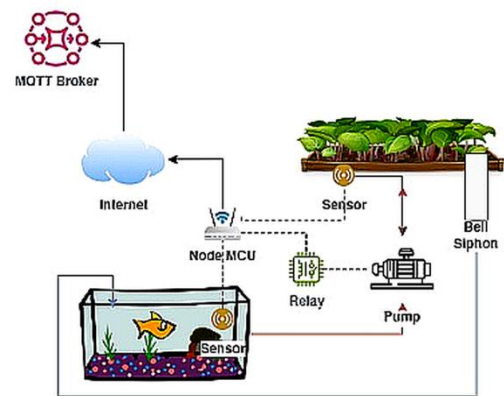

Fig. 3 Standard Aquaponics Plantation

ii. Vehicles, smart transportation, and AIoT

Smart technologies that link infrastructure, cars, and passengers through the Internet of Things are revolutionising the transportation industry. Through vehicle-to-vehicle and vehicle-to-infrastructure communication, these systems improve safety, enable predictive vehicle maintenance, and support cutting-edge technologies like autonomous and electric vehicles. Smart transportation systems powered by the internet of things (IoT) offer connected, safe, and efficient transportation experiences while enhancing traffic flow, reducing congestion, and promoting sustainable urban growth. Examples include Internet of Things (IoT) gadgets like cameras and sensors that smart parking applications utilise to monitor parking availability and provide reservation options[9]. To find available parking spaces, machine learning systems examine photos of parking lots. Magnetic and ultrasonic sensors are used to keep track of parking space availability[9].

Users can get real-time parking information through mobile applications or smart signboards, and cloud servers collect and interpret sensor data. Car identification and tracking are made possible using RFID technology. Smart parking systems have high success rates, according to a reliability study[9]. Moreover, in a smart city, smart transport services include smart street lights (SSL), which are an essential component. SSL systems enable energy economy, energetic operation, and management by utilizing IoT technology[9]. These intelligent lights include wireless communication modules as well as GPS, IR, and light sensors. Depending on the volume of people, they can change the light intensity, increasing safety and using less energy. Using GPS and NB-IoT network connectivity, a central system keeps track of the whereabouts and condition of lighting[9]. Fog nodes collect data from

<https://doi.org/10.31436/ijpc.v10i1.414>

multiple lamps, enabling automated operations and remote management. Some versions automate on/off switching depending on dawn, sunset, and the detection of passing vehicles or pedestrians using micro-controllers like the Raspberry Pi, light sensors, and IR sensors[9]. Furthermore, smart lighting systems might include lamp posts that have WiFi hotspots, cameras, and environmental sensors to improve safety in emergency situations and supply information to central web servers[9]

iii. Energy, smart grids, and AIoT

Figure 4 portrays the smart home energy management proposal plan. Energy, smart grids, and AIoT are revolutionizing the energy sector. Smart grids use cutting-edge technology to improve energy distribution, incorporate renewable energy sources, and facilitate two-way communication. By gathering and analyzing data, AIoT improves smart grids by enabling predictive maintenance and effective energy management. This integration promotes sustainable growth, optimizes energy use, and increases system resilience. An example is the IoT system for smart home energy management (SHEMS)[10]. The objective is to show how AIoT could affect daily life. The SHEMS collects and stores information about home appliances, shows energy use, and takes appropriate action.. The system adds high-performance data processing and prediction skills from integrating AI, enabling it to save energy use by deftly managing appliances[10]. Although there are no actual IoT devices present in this implementation—it is entirely analytical—a dataset of electricity use over a nine-year period was used for simulation. To code and compare various strategies to get the desired results, MATLAB was used[10].

Next is state estimation. State estimation (SE) is a method for performing monitoring tasks in power grids that make use of static data and real-time observations to estimate the system's status. Bad Data Analysis, which locates measurement inaccuracies brought on by faulty meters or cyberattacks, is a key application. In the literature, False Data Injection (FDI) is a common type of cyberattack in which attackers fiddle with measurements[10]. Existing FDI detection strategies concentrate on simulating attack behaviour and using load forecasting with machine learning techniques to spot minute changes in load distribution or state variables of the power grid[10]. However, these techniques frequently ignore coordinated operations involving several hackers and miss other kinds of cyberattacks that can impair the performance of the power system.

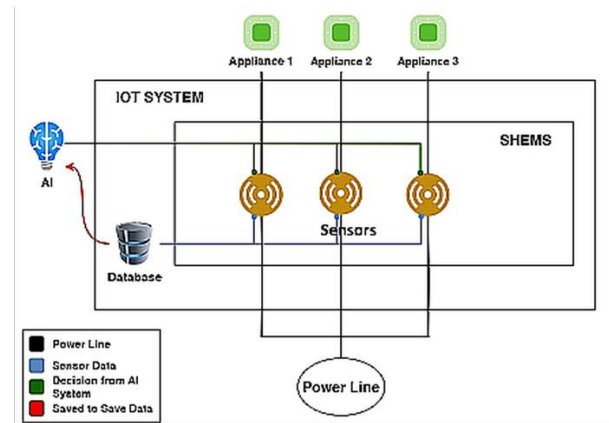

Fig. 4 Smart Home Energy Management Proposal Plan

iv. Industry, smart buildings, and IoT

The fusion of business, smart buildings, and IoT is revolutionizing operational and managerial procedures. Real-time monitoring, proactive maintenance, and efficient resource use are all made possible by IoT technologies. Smart buildings use IoT to increase efficiency, tenant comfort, and overall performance. Convergence fuels digital change, enhancing sustainability and operational effectiveness. Some ways for this is by utilizing current intranet infrastructure, the convergence of IoT, PoE (Power over Ethernet), and IP (IPv4 and IPv6) is improving surveillance functionality. Higher power is needed for advanced security cameras, hence PoE+, 4PPoE, and IP/IoT-based designs are perfect[11]. Box, dome, and PTZ cameras are available, although fixed-view and 360-degree cameras are starting to overtake PTZ in terms of usage due to cost and maintenance considerations. Protocols such as TCP/IP, UDP/IP, IGMP, UPnP, DNS, DHCP, RTP, RTSP, and NTP are used in IP-based video surveillance systems[11]. Giving a bigger impact on the industry. Other than that is IoT-based lighting control which is essential for managing smart buildings. Although several vendor-specific strategies have been employed, adopting standards-based procedures would be beneficial. PoE, which supports data/VoIP connectivity, IoT power, and access to aggregate points, has benefits for lighting applications. The adoption of PoE-based technologies, also referred to as "networked lighting" or "lighting digitalization," [11] has made it possible to integrate LED lighting systems. Low-voltage LED lighting is allowed to use PoE as a class 2 power supply per UL-2108 [11]. Furthermore, improvements in organic LED technology are worth keeping an eye on for expanded use in lighting systems.

v. Biomedical, smart health, and AIoT

The fusion of biomedical, smart health, and AIoT (Artificial Intelligence of Things) is totally changing the healthcare business. Smart health systems provide real-time health data collecting, remote patient monitoring, and

<https://doi.org/10.31436/ijpcc.v10i1.414>

individualized healthcare services by fusing IoT devices and AI capabilities. To deliver insights, early disease diagnosis, and predictive analytics for better diagnoses and treatment planning, AI systems analyze the enormous amount of acquired data. This combination improves patient care, makes proactive health management possible, and helps to deliver healthcare more quickly and effectively. An example is Non-Contact Monitoring: Many applications for health monitoring can benefit from including environmental monitoring tools like cameras or radar[12]. An AIoMT (Artificial Intelligence of Medical Things) system for tracking fatigue was created in a recent work, combining data from forehead-worn EEG sensors and video-derived eyelid characteristics for classification using SVM and LSTM models. It was discovered that LSTM can detect fatigue with up to 75.71% accuracy without any user calibration [12]. It was also discovered that SVM when tailored to a specific person, can detect fatigue with up to 99.64% accuracy[12].

Surprisingly, models trained on merged data only marginally outperformed models trained only on eyelid features but greatly outperformed models trained alone on EEG data [12]. Next, AIoMT (Artificial Intelligence of Medical Things) was also created to keep an eye out for indicators of heat stroke in workers working in hot conditions. The system included wearable gadgets with sensors for temperature, PPG (photoplethysmography), humidity, and vibration. Metrics including heart rate, activity, and personalized heat stress temperature were examined using machine learning models[12]. Unexpectedly, a straightforward k-nearest neighbors model fared better at detecting heat stroke than more sophisticated algorithms like RF and SVM [12]. The technology was evaluated in a hot workplace environment and successfully detected 96.7% of cases of heat stroke[12]. This demonstrates the potential of wearable monitoring for applications in workplace health and safety.

vi. Robotics and computer vision in AIoT

In the Internet of Things, the result of computer vision and robotics with artificial intelligence (AI) produced a great combination of AIoT. In smart agriculture, both robotics and computer vision were some of the methods applied in seeking the advancements and problems to be used in the area using AIoT. Computer vision was also used to improve the algorithm and to be utilized. It was also used as a monitoring system for the growth rate of tomatoes. Making use of an R-CNN (regional-based convolution neural network)[13]. Artificial neural networks (ANN), KNN, and support vector machines (SVM) are further techniques that are employed[13]. The enormous expansion of agricultural data often gathered through IoT sensor devices makes a smart agriculture system based on computer vision promising[13]. It's anticipated that technologies like AI, robotics, and the Internet of Things will revolutionize

society's technological landscape. These cutting-edge technologies hold the promise of creating a society where communication knows no boundaries, where people and machines live in harmony, and where networks are trustworthy and safe. Some particular solutions are suggested, including large-scale image security solutions, dam detection robots, and automatic translation solutions[14]. Multiple robots designed to be able to detect danger situations in aerial, on surface, underwater, underground with cloud AI to restore their abilities to sense and perform several tasks[14]. Some were also designed for search and rescue in disasters based on AI and IoT. They would collect "sensory data" from its surroundings and transmit it to local workstations for additional cloud computing (training, validation). The findings demonstrate that artificial intelligence-based decision-making is better appropriate for the context of catastrophe response[14].

vii. Security in IoT

In this modern days, By using Artificial Intelligence(AI), it will help the IoT devices such as sensors to act faster and more efficient by learning from the data[15]. For example, the sensor will be able to detect if anything wrong happens in the network. By using AI in the security system, it also can narrow the probability of getting cyber threats. The communications between IoT devices will also be more effective while preventing the cyber threats[16]. This is because Ai will learn the behaviour of the network and it will adapt with the surrounding. For example in a big scale such as smart cities, if there is a framework that focuses on the IoT communication protocols, it will be much more effective there is AI involved rather than smart cities that only focus on bunch of IoT. It will be able to monitor the security of the network as AI will be able to acquire, store and analyze all the data and big data provided by the IoT devices[16].

AI-based IDS is also good to be used in the security system. It is because AI-based IDS is superior in their ability to identify threats autonomously. The software layer analyses incoming traffic packets in the early stages of their design process and selects features. In the second step, the system classifies the packets, and if an attack is detected, the necessary controls will be executed and decides on network limits. In comparison, AI-based IDS is much more better than BAT algorithm as it shows that computation time to discover important features is reduced and it also gives a fast response compared to BAT algorithm[16]. It is because BAT algorithm lacks parallel processing and self-adaptive abilities.

II. LITERATURE OVERVIEW

This literature overview provides a brief summary of at least 16 papers published from 2018 onward of key sources on the Distributed sensor networks in the Internet of Things.

<https://doi.org/10.31436/ijpcc.v10i1.414>

Appendix 1 shows a few previous articles related to distributed sensor networks in the internet of things.

III. METHODOLOGY

This review paper follows a systematic approach to gather, analyze, and synthesize relevant literature on the topic of "Artificial Intelligence: A New Paradigm for Distributed Sensor Networks in the Internet of Things." The methodology involves the following steps:

Literature Search: A comprehensive search was conducted across various academic databases, including but not limited to IEEE Xplore, ACM Digital Library, ScienceDirect, and Google Scholar. Keywords such as "Artificial Intelligence," "Internet of Things," "Distributed Sensor Networks," and related terms were used to identify relevant research articles, conference papers, and review papers.

Inclusion and Exclusion Criteria: Articles were screened based on predefined inclusion and exclusion criteria. Only studies published in English and within a certain timeframe were considered. Relevant papers focusing on the convergence of architectures, techniques, platforms, sensors, devices, energy approaches, communication, networking, and applications for AIoT were included.

Data Extraction and Analysis: Pertinent information from selected articles was extracted and organized. The key findings, methodologies, and conclusions of each study were carefully examined and synthesized to identify common themes, trends, and insights.

Significance of AIoT in sensor networks: Based on the findings from the literature review, recommendations for innovation and future research were proposed. The conclusions drawn from the synthesized information provide a comprehensive understanding of the current state, challenges, and potential of AI-based sensors in distributed sensor networks within the Internet of Things

IV. SIGNIFICANCE OF AIOT IN SENSOR NETWORKS

A. *Intelligence Enhance sensor*

To propel the field of AI-based sensors in IoT systems, it is crucial to focus on advancing sensor intelligence. This may be accomplished by incorporating advanced machine learning and deep learning algorithms into sensor devices. Researchers might investigate approaches like reinforcement learning and generative adversarial networks that allow sensors to adapt, learn, and make autonomous judgements based on changing data patterns. AI-powered sensors may become more skilled at spotting complicated patterns, generating accurate predictions, and offering important insights in real-time through improving sensor intelligence. This improvement will enable more exact decision-making and proactive responses for IoT applications, enabling more precise decision-making and proactive replies.

B. *Improve energy efficiency*

Energy efficiency is an important consideration in the development of AI-based sensors for IoT systems. Researchers should focus on building energy-efficient sensor designs and investigating energy collecting approaches to innovate in this field. The overall sustainability of IoT installations may be improved by extending sensor lifespans and lowering power usage. Investigating the use of renewable energy sources, optimizing algorithms for low power consumption, and implementing low-power communication protocols are all viable ways to improve energy efficiency in AI-based sensors. IoT systems may function reliably and sustainably for prolonged periods of time by prioritizing energy-aware design and resource optimisation, decreasing the need for frequent battery changes and minimizing environmental effect.

C. *Ensure data security and privacy*

In the evolution of AI-based sensors in IoT systems, addressing data security and privacy concerns is critical. Researchers should create strong encryption approaches, authentication protocols, and privacy-preserving algorithms to promote innovation in this field. Sensitive sensor data can be secured from unauthorised access or alteration by employing robust security measures. Investigating strategies like federated learning, differential privacy, and safe aggregation can help with secure and privacy-conscious AIoT installations. Establishing data protection and privacy rules and guidelines can instill trust among users and stakeholders, enabling wider use of AI-based sensor technologies while protecting individuals' private rights.

V. CONCLUSION

In conclusion, the incorporation of AI-based sensors in IoT systems represents a disruptive paradigm with enormous promise for numerous industries. The confluence of AI and IoT technology has created new opportunities for gathering, analysing, and using sensor data to make intelligent real-time choices. AI-powered sensors boost performance, efficiency, and the capacity to identify new patterns and insights in large datasets. They allow proactive monitoring, predictive maintenance, and intelligent decision-making, transforming Internet of Things applications in healthcare, agriculture, transportation, and manufacturing. However, issues like data security, privacy, and energy efficiency must be addressed. Recommendations for furthering innovation include boosting sensor intelligence, increasing energy efficiency, assuring data security and privacy, fostering interoperability, and encouraging cross-disciplinary research. By adhering to these guidelines and addressing ethical considerations, the full potential of AI-based sensors can be harnessed, leading to the development of next-

<https://doi.org/10.31436/ijgcc.v10i1.414>

generation IoT applications that enhance autonomy, accuracy, and sustainability. The future presents tremendous prospects for breakthroughs in AI-based sensor technologies, which will drive innovation and alter industries, eventually leading to a more intelligent and linked society.

ACKNOWLEDGEMENT

We would like to express our sincere gratitude to the Computer Network course for greatly advancing our comprehension of AIoT and sensor networks. Our understanding of these crucial fields has been significantly shaped by the information we've gained through studying this topic, and it has given us the tools we need to efficiently research and employ these technologies' potential. We sincerely thank our esteemed professors and educators for their unwavering dedication and diligent efforts in disseminating this essential knowledge, which has helped us advance in improving our proficiency and comprehension in the fields of computer networking, sensor networks, and the Internet of Things.

CONFLICT OF INTEREST

The authors declare that there is no conflict of interest.

REFERENCES

- [1] K. Umeda, T. Nishitsuji, T. Asaka, and T. Miyoshi, "Distributed processing method for deep learning in wireless sensor networks," *IEICE Commun. Express*, vol. 10, no. 8, pp. 505–510, Aug. 2021, doi: 10.1587/comex.2021ETL0029.
- [2] Y. Sun, J. Zhang, Y. Xiong, and G. Zhu, "Data Security and Privacy in Cloud Computing," *Int. J. Distrib. Sens. Netw.*, vol. 10, no. 7, p. 190903, Jul. 2014, doi: 10.1155/2014/190903.
- [3] L. Sun, X. Jiang, H. Ren, and Y. Guo, "Edge-Cloud Computing and Artificial Intelligence in Internet of Medical Things: Architecture, Technology and Application," *IEEE Access*, vol. 8, pp. 101079–101092, 2020, doi: 10.1109/ACCESS.2020.2997831.
- [4] S. Cheng, Z. Cai, and J. Li, "Approximate Sensory Data Collection: A Survey," *Sensors*, vol. 17, no. 3, p. 564, Mar. 2017, doi: 10.3390/s17030564.
- [5] S. C. Mukhopadhyay, S. K. S. Tyagi, N. K. Suryadevara, V. Piuri, F. Scotti, and S. Zeadally, "Artificial Intelligence-Based Sensors for Next Generation IoT Applications: A Review," *IEEE Sens. J.*, vol. 21, no. 22, pp. 24920–24932, Nov. 2021, doi: 10.1109/JSEN.2021.3055618.
- [6] S. Kiran, U. V. Kumar, and T. M. Kumar, "A Review of Machine Learning Algorithms on IoT Applications," in *2020 International Conference on Smart Electronics and Communication (ICOSEC)*, Trichy, India: IEEE, Sep. 2020, pp. 330–334. doi: 10.1109/ICOSEC49089.2020.9215430.
- [7] K.-C. Chang and M.-H. Chiang, "Design of Data Reduction Approach for AIoT on Embedded Edge Node," in *2019 IEEE 8th Global Conference on Consumer Electronics (GCCE)*, Osaka, Japan: IEEE, Oct. 2019, pp. 899–900. doi: 10.1109/GCCE46687.2019.9015421.
- [8] V. K. Quy et al., "IoT-Enabled Smart Agriculture: Architecture, Applications, and Challenges," *Appl. Sci.*, vol. 12, no. 7, p. 3396, Mar. 2022, doi: 10.3390/app12073396.
- [9] F. Zantalis, G. Koulouras, S. Karabetos, and D. Kandris, "A Review of Machine Learning and IoT in Smart Transportation," *Future Internet*, vol. 11, no. 4, p. 94, Apr. 2019, doi: 10.3390/111040094.
- [10] A. K. Salama and M. M. Abdellatif, "AIoT-based Smart Home Energy Management System," in *2022 IEEE Global Conference on Artificial Intelligence and Internet of Things (GCAIoT)*, Alamein New City, Egypt: IEEE, Dec. 2022, pp. 177–181. doi: 10.1109/GCAIoT57150.2022.10019091.
- [11] D. Minoli, K. Sohraby, and B. Occhiogrosso, "IoT Considerations, Requirements, and Architectures for Smart Buildings—Energy Optimization and Next-Generation Building Management Systems," *IEEE Internet Things J.*, vol. 4, no. 1, pp. 269–283, Feb. 2017, doi: 10.1109/JIOT.2017.2647881.
- [12] S. Baker and W. Xiang, "Artificial Intelligence of Things for Smarter Healthcare: A Survey of Advancements, Challenges, and Opportunities," *IEEE Commun. Surv. Tutor.*, vol. 25, no. 2, pp. 1261–1293, 2023, doi: 10.1109/COMST.2023.3256323.
- [13] H. K. Adli et al., "Recent Advancements and Challenges of AIoT Application in Smart Agriculture: A Review," *Sensors*, vol. 23, no. 7, p. 3752, Apr. 2023, doi: 10.3390/s23073752.
- [14] M.-F. R. Lee and T.-W. Chien, "Artificial Intelligence and Internet of Things for Robotic Disaster Response," in *2020 International Conference on Advanced Robotics and Intelligent Systems (ARIS)*, Taipei, Taiwan: IEEE, Aug. 2020, pp. 1–6. doi: 10.1109/ARIS50834.2020.9205794.
- [15] M. Andronie, G. Lăzăroiu, M. Iatagan, C. Uță, R. Ștefănescu, and M. Cocoșatu, "Artificial Intelligence-Based Decision-Making Algorithms, Internet of Things Sensing Networks, and Deep Learning-Assisted Smart Process Management in Cyber-Physical Production Systems," *Electronics*, vol. 10, no. 20, p. 2497, Oct. 2021, doi: 10.3390/electronics10202497.
- [16] K. P. Seng, L. M. Ang, and E. Ngharamike, "Artificial intelligence Internet of Things: A new paradigm of distributed sensor networks," *Int. J. Distrib. Sens. Netw.*, vol. 18, no. 3, p. 15501477211062835, Mar. 2022, doi: 10.1177/15501477211062835.

Appendix 1: Survey of Distributed sensor networks in the Internet of Things.

Articles	Content	Advantages/Disadvantages
[1]	They propose using their arithmetic calculation to divide the intermediate level of the deep learning by the sensors processing capability and the communication. This is because the studies that they've researched about only focuses on the processing speed and the latency while their solution reduce communication volume and server load	<p>Advantages</p> <ul style="list-style-type: none"> • Delays and computational complexity are reduced when choosing the size of DNN <p>Disadvantages</p> <ul style="list-style-type: none"> • DNN execution is dependent on the bandwidth and delay. DNN may be execute on the edge server
[2]	Cloud computing is the study's primary goal. According to the author, cloud computing provides flexible access to a pool of shared programmable computing resources. The author also points out that cloud computing is still very new within the context of computing. Cloud computing is also renowned for being economical. The three widely used service models in the cloud paradigm are also covered in the paper: <ul style="list-style-type: none"> • Software as a service (SaaS) • Platform as a service (PaaS) • Infrastructure as a service (IaaS) 	<p>Advantages</p> <ul style="list-style-type: none"> • Cloud computing offers minimal cost and virtual service that can be accessed anywhere by the user <p>Disadvantages</p> <ul style="list-style-type: none"> • User need to trust fully the cloud service provider with sensitive data
[3]	The paper focuses on the architecture of the Internet of Medical Things (IoMT). The study highlights the existence of several proposed architectures for the Internet of Things (IoT), which include: <ul style="list-style-type: none"> • Web of things architecture • EPCglobal architecture • Sensor network-based architecture • Autonomous architecture • Machine to Machine (M2M) architecture <p>Within the realm of IoT, the M2M architecture stands out as the most widely adopted. M2M architecture encompasses relevant aspects of EPCglobal and Wireless Sensor Network (WSN). The author of the paper emphasizes that IoMT represents the application of IoT technology within the medical field. IoMT follows a three-tier architecture for IoT applications, consisting of the perception layer, network layer, and transmission layer.</p>	<p>Advantages</p> <ul style="list-style-type: none"> • Save time on recording and sorting patients medical information <p>disadvantages</p> <ul style="list-style-type: none"> • Medical records contain patients personal information that can be damaging if the security is breached and the patient's information is leaked
[4]	The primary focus of this study is Sensory Data. In the introductory section, the author highlights the essential link between IoT and wireless sensor networks. Within these systems, the procedure for handling sensory data can be categorized into three distinct phases:	<p>Advantages</p> <ul style="list-style-type: none"> • With IoT in place the connectivity of receiving data will be analyse and compute seamlessly <p>disadvantages</p> <ul style="list-style-type: none"> • Limitation on the nodes caused less raw data to be collected and received

	<ul style="list-style-type: none"> ● Acquisition of Sensory Data ● Collection of Sensory Data ● Computation of Sensory Data 	
[5]	<p>This article investigates the role of artificial intelligence (AI) in IoT systems, covering different architectures, sensor data processing, communication technologies, and motives for enabling intelligence in IoT contexts. It emphasises the significance of efficient, intelligent, context-aware, trustworthy, accurate, and linked sensors in smart IoT applications to accomplish automation.</p>	<p>Advantages</p> <ul style="list-style-type: none"> ● In smart sensing systems, combining AI with IoT increases decision-making, productivity, and cost savings. AI-powered real-time data analysis allows for more informed decisions, increases operational efficiency, and finds areas for development. Through predictive capabilities, AI also assists in preventive maintenance and decreases downtime. <p>disadvantages</p> <ul style="list-style-type: none"> ● Integrating AI and IoT with smart sensing devices raises the possibility of cybersecurity attacks and data breaches. As more data is collected and analysed, privacy issues develop. Furthermore, the expense of integrating these technologies may be too expensive for small businesses or those with limited means.
[6]	<p>This paper gives an in-depth examination of machine learning techniques for IoT applications. The authors examine the benefits and problems of using machine learning in IoT systems, as well as the expanding relevance of IoT in numerous industries, including manufacturing. They also offer decision tree algorithms as a possible technique to boosting IoT application performance. This article provides useful insights into the most recent trends and advancements in this dynamic topic, making it an excellent addition to any literature review on machine learning and IoT.</p>	<p>Advantages</p> <ul style="list-style-type: none"> ● Machine learning in IoT enhances efficiency, accuracy, and decision-making by analyzing vast data volumes. For instance, in a smart home, it learns user behavior and adjusts settings accordingly. In industrial settings, it optimizes manufacturing processes, reducing downtime. <p>Disadvantages</p> <ul style="list-style-type: none"> ● IoT machine learning raises concerns of data privacy and security due to sensitive data collection. It requires substantial computational power and storage, limiting scalability and increasing costs. Poorly trained algorithms may yield biased or inaccurate results, posing further challenges in IoT applications.
[7]	<p>The paper presents a data reduction strategy for conveying sensor data in the age of Internet of Things (IoT) and Artificial Intelligence (AI) technologies. The authors emphasise the difficulties presented by the increasing volume of data transmitted by linked devices, as well as the related connectivity and storage needs. To address these issues, they suggest an IoT architecture based on the MQTT communication protocol that employs edge devices to collect data. The suggested data reduction method can drastically decrease the amount of sensor data while keeping its analytical properties. The authors use this architecture to collect sensor data in a precision machinery factory in Taichung. Overall, this work offers a practical strategy for optimising data transfer and collecting on edge</p>	<p>Advantages</p> <ul style="list-style-type: none"> ● It improves data transfer and collecting on edge devices by removing certain superfluous IoT data. This reduces the communication and storage overhead, making it easier to acquire and interpret sensor data for future deep-learning applications. Second, to efficiently minimise back-end loads and traffic, the design employs edge computing with high-performance edge devices. This improves data gathering and processing efficiency while minimising the load on central servers. <p>Disadvantages</p> <ul style="list-style-type: none"> ● The potential restriction is that the suggested design may necessitate the installation of extra hardware or software components on edge devices, which might raise implementation costs. Furthermore, while eliminating duplicated data might assist to optimise

	devices that may be implemented to AIoT for factory data collection.	communication and storage needs, it may result in some data loss that could be helpful for analysis. As a result, it is critical to carefully weigh the advantages of data minimization against the possible costs of missing key insights from sensor data
[8]	This research focuses on agriculture and we chose to focus on aquaponics and forestry. Both play important role because it uses AIoT in some way. In aquaponics the authors designed an IoT system to keep an eye on the water's temperature and pH level for aquaponics farms. For forestry the author built an Internet of Things (IoT) system to maintain track of environmental factors like temperature, humidity, wind direction, barometric pressure, and disaster management. IoT devices use the solar-powered system and connect to the monitoring center via the LoRa network to increase viability.	<p>Advantages</p> <ul style="list-style-type: none"> ● Efficiency gain: AIoT technologies give farmers the ability to optimise farming methods including pest control and resource use, resulting in greater efficiency and enhanced agricultural output. <p>Disadvantages</p> <ul style="list-style-type: none"> ● Initial cost and complexity: Small-scale farmers may find it difficult to afford to implement AIoT technologies in agriculture because they may need to invest significantly in infrastructure, tools, and training.
[9]	We found out that the application of AIoT also performs in transportation. Here the center of attention would be the smart parking by using a smart signboard to portray related details. By using ultrasonic sensors to inform which car park is empty. The other key point would be Smart Street Lights(SSL). These are used to conserve energy with the use of light, IR, and wireless communication modules.	<p>Advantages</p> <ul style="list-style-type: none"> ● IoT-enabled smart transportation systems can increase safety by providing real-time hazard detection, collision avoidance, and traffic management through vehicle-to-vehicle and vehicle-to-infrastructure communication. <p>Disadvantages</p> <ul style="list-style-type: none"> ● Dependence on connectivity: IoT-enabled transportation systems depend largely on consistent, uninterrupted connectivity, and any network connectivity issues can affect their dependability and effectiveness.
[10]	The combination of an AI system and a SHEMS (Smart Home Energy Management IoT System) is discussed in this study as a straightforward theoretical and simulated implementation. The main objective of this implementation is to further illustrate the significant influence that AIoT will have on our daily life. SHEMS may gather data from home appliances, store it, show the homeowner how much energy is being used, and take action if necessary. This system is completely static because it only carries out instructions exactly as given. Such a system's capabilities for data gathering and storage might be advantageous to an AI system fused with it.	<p>Advantages</p> <ul style="list-style-type: none"> ● Better energy distribution is made possible by smart grids, which use cutting-edge technology to continuously monitor, regulate, and optimise the flow of energy. <p>Disadvantages</p> <ul style="list-style-type: none"> ● Compatibility and interoperability issues can arise when integrating numerous technologies, systems, and devices from different players in the energy industry; these issues call for standardised protocols and cooperation.
[13]	An overview of current developments and difficulties in the use of AIoT (Artificial Intelligence of Things) in smart agriculture is given in this article. The advantages of utilising AIoT in agricultural, such as increasing yields and cutting	<p>Advantages</p> <ul style="list-style-type: none"> ● Real-time farm monitoring using AIoT may assist farmers in making educated decisions regarding irrigation, fertilisation, and other aspects that influence crop development and production.

	<p>costs, are discussed in the paper along with the difficulties in adopting AIoT in agriculture and how to overcome them. The most potential AIoT technologies and applications now being created for usage in agriculture are also listed by the writers, along with how they could change the sector in the upcoming years. The report offers citations to pertinent papers and other sources to back up its assertions.</p>	<ul style="list-style-type: none"> ● Effective agricultural data analysis: Farmers may make data-driven decisions regarding their farming practises by using AIoT to swiftly and accurately analyse vast volumes of agricultural data. <p>Disadvantages</p> <ul style="list-style-type: none"> ● Infrastructure gaps: In certain places, the infrastructure required to support AIoT systems may not be there, making it challenging to properly install these systems.
[14]	<p>From the paper, we can see how AI, IoT, and robotics are interconnected in performing hard tasks as multiple of them rather than a single one. Robots that's designed for when disaster happens. With few robots for each category:</p> <ul style="list-style-type: none"> ● Aerial module ● Ground module ● Surface module ● Underwater module ● AI module <p>They connected the bots to Ai cloud server for best decision making. The last module is a data transfer module for faster and better than to the cloud. The findings demonstrate that AI based decision making is better and appropriate for catastrophe response.</p>	
[15]	<p>This paper gives several reasons why AI plays an important part with the IoT in order to improve the security system from the cyber threats. This paper also provides some methods that has been proposed by the researcher in order to test whether implementing AI with the IoT devices is giving positive impact or not. Some of it are:</p> <ul style="list-style-type: none"> ● proposed a framework for the IoT enabled smart city using AI ● using AI- based ISD 	
[16]	<p>The author addresses the difficulties associated with the growth of wireless sensor networks in the paper's introduction, particularly the risk of server overload. As a solution, the author suggests employing edge computing and mobile devices to enable distributed processing for deep learning. Additionally, the author proposes a method for parallel processing of convolutional layers, leveraging multiple mobile terminals.</p>	
[11]	<p>In this reference, we find that by utilizing current intranet infrastructure, the convergence of IoT, PoE, and IP technology is improving surveillance capabilities. There is also Lightning control using IoT. With this it reduces the labor and material</p>	<p>Advantages</p> <ul style="list-style-type: none"> ● IoT in smart buildings enables the effective use of resources like electricity, water, and waste management. This results in cheaper expenses, a less negative impact on the environment, and more

	<p>expenses associated with the installation while frequently accelerating the installation process, enables the control of smart lights, and allows for integration</p>	<p>sustainability.</p> <p>Disadvantages</p> <ul style="list-style-type: none"> Managing IoT systems in smart buildings calls for specialised knowledge and abilities. Building owners and operators who want to manage system setup, maintenance, and troubleshooting must either invest in training or hire specialists who are knowledgeable with IoT
<p>[12]</p>	<p>Based on this we highlighted 2 main pieces of information which use wearable monitoring and non-contact monitoring. AloMT was created with the goal of maintaining surveillance out for heat stroke symptoms in workers in hot situations while non-contact monitoring developed a fatigue monitoring system combining data from forehead-worn EEG sensors with video-derived eyelid data.</p>	<p>Advantages</p> <ul style="list-style-type: none"> By offering real-time data, personalised suggestions, and proactive health monitoring, smart health systems enable people to take control of their health, which improves preventative care and lifestyle management. <p>Disadvantages</p> <ul style="list-style-type: none"> The instructional data's quality and accuracy have a significant impact on the accuracy and reliability of AI algorithms. Making wise healthcare decisions depends on the algorithms being precise, objective, and verified.