

A New Topology for High-Efficiency DC-DC Hybrid Boost-SEPIC Converter to Offer the Optimum Output From PV Panel

Khadiza Akter¹, S. M. A. Motakabber^{1*}, AHM Zahirul Alam¹ and Siti Hajar Yusoff¹

¹Dept. of ECE, Faculty of Engineering, IIUM, 53100 KL, Malaysia

*Corresponding author: amotakabber@iium.edu.my

(Received: Day Month Year; Accepted: Day Month Year)

Abstract— This paper initiates a high gain high adaptability step-up DC-DC converter based using Boost-SEPIC hybrid topology for solar and industrial applications. Customarily DC-DC converter circuit is a widely used technique to improve the voltage level of a solar cell. However, for low output voltage and low efficiency, they are not sufficient to provide expected outcomes. To defeat the conventional system a modified Boost-SEPIC topology has been recommended with enhanced performance. The proposed design of the DC-DC converter circuit can provide a high voltage gain without decaying its overall performance. A single switch with low switching voltage stress is working the modified converter topology over the semiconductor devices. The main edge of the proposed design is it can perform efficiently without using any transformer, the combined design of Boost-SEPIC topology increases the voltage gain much higher compared to the conventional Boost or SEPIC converter. The power simulator software has analyzed the performance of the proposed designed converter circuit thoroughly.

Keywords: Step-up Converter, High voltage gain, SMPS, MOSFET Switch.

1. INTRODUCTION

In recent years, the fast ascent in power demand and the change in biological circumstances, for example, the rise of worldwide temperature by using traditional energy sources, for example, consumption of oil and coal brings about the development the greenhouse impact and contamination issues in the environment. It expands the need for novel assets of energy, which is modest and increasingly maintainable. Due to several reasons, the use of renewable energy is highly increased as clean and sustainable energy. From the available resources of renewable energy, solar energy is the biggest contributor to clean emission-free and inexpensive energy [1]. For the increasing demand for renewable energy systems, photovoltaic systems and semiconductors, the industry requires wide use of high-efficiency DC-DC power electronic converters. The output voltage levels from these sources are commonly low and unregulated and it doesn't coordinate with the load and should be expanded [2]. The most feasible and efficient way to increase the low voltage of a PV array and reduce the voltage strains on semiconductor components, according to several researchers, is to use high step-up DC-DC converters [3]. The easiest architectures for achieving a high-voltage gain are cascaded and multilayer converters; however, because of the numerous stages and numerous power switches, they have low efficiency [4]. The output voltage of a PV cell usually ranges from 12 V to 50 V. Inherently DC-DC step-up converter is being used for increasing the voltage level and output gain of solar energy [5]. Fig.1 present a PV system where A DC-DC step-up converter is used to increase the output voltage of the PV source, which can be converted again to an AC output through an inverter to the load [6]. A high-frequency transformer can build the desired output however; it has a certain disadvantage of leakage current due to the inductance of the transformer [7]. Nevertheless, to improve the productivity, just as diminish the absolute leakage current, the converter without a transformer is examined

throughout this research. Over the years, many solutions and topologies have been proposed by the researchers for the improvement of the overall power quality of DC-DC converters, however, most of them suffer from low gain and low efficiency [2], [7]–[12]. The proposed topology introduces a hybrid DC-DC converter with a solitary switch. Topology consolidates two traditional DC-DC converters to improve the output gain without interfacing a mid-point transformer [13].

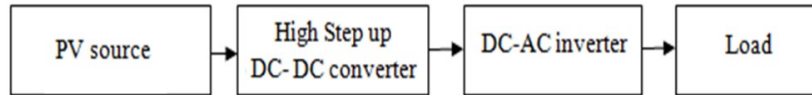

Fig.1. A typical step-up DC-DC converter with a photovoltaic system

A conventional DC-DC converter experiences some power losses like losses in MOSFET, input and output capacitance loss, diode loss, inductor losses etc. The total power losses in a boost converter are the sum of all factors. In the case of SEPIC, similar difficulties are seen and the inductor and capacitor resistance affect the efficiency and output ripple voltage [5]. DC-DC boost converter system is useful to increase the output voltage level. Due to the leakage resistance of the inductor, the performance of the conductor decreases with the increasing duty cycle ratio of the switching. Therefore, a traditional boost converter cannot be used for high voltage requirements [6]. The convergence of this paper is firstly to build up a DC-DC converter with a mix of boost and SEPIC together. It has significant merits such as high voltage gain and high efficiency, which makes this design a good choice to be implemented. Additionally, the altered converter has been contrasted and different sorts of converters dependent on similar parameters and has been analyzed the performance of the adjusted boost SEPIC converter. The control of the proposed converter is simple because a single switch is utilized.

2. MODELLING OF MODIFIED DC-DC BOOST-SEPIC CONVERTER

The proposed circuit appeared in Fig. 2 is formed by the boost converter and SEPIC converter. The major primacy of this converter is to lessen the number of switches and inductors contrasted with the isolated converters. For the most part, the voltage stress over the switch is in addition diminished alongside the decrease in input current ripple. For analysis, the two converters have used a similar DC input voltage.

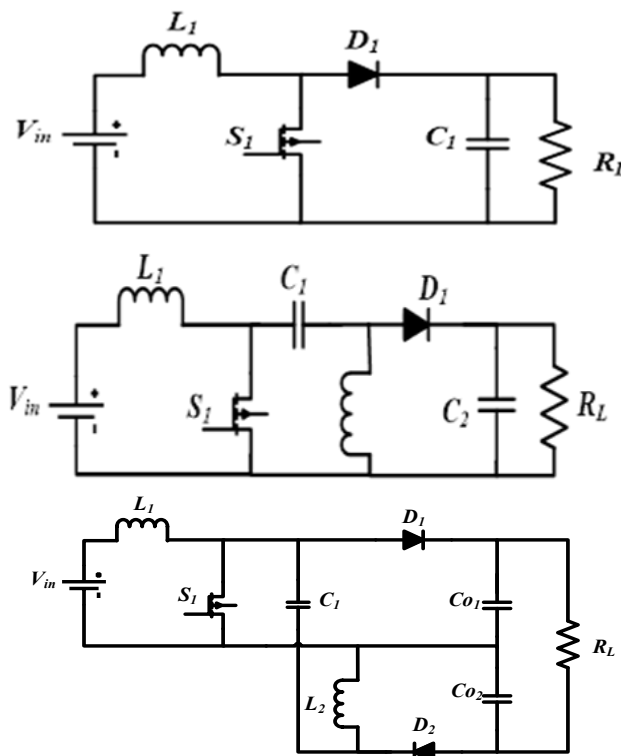

Fig. 2. Proposed DC-DC Boost-SEPIC converter

Mode-1 (Switch ON Mode)

When the switch S_1 is turned on, the diode D_1 does not directed for reverse biased, in this way, the current in inductor L will build, C_1 and C_2 are charged equally. Current will continue to flow in a flowing way as given in Fig.3

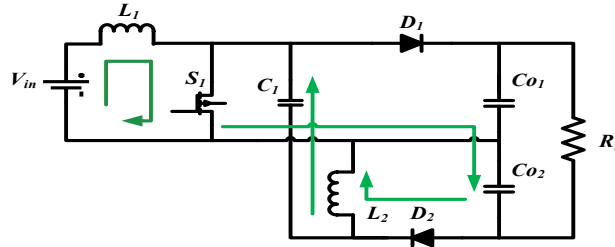

Fig. 3. Switch On mode (Mode-1)

Mode-2 (Switch off mode)

When the MOSFET switch S_1 is off; the Diode D_1 has led for Its forward one-sided voltage. The inductor will release its stored energy and the current will continue to flow as shown in Fig. 4.

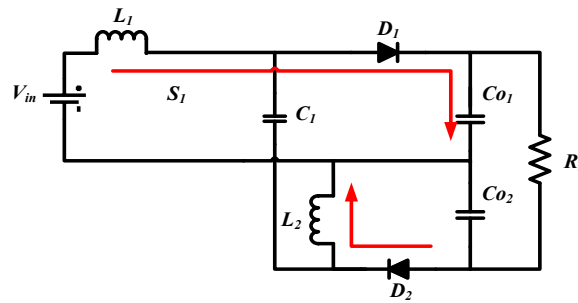

Fig. 4. Switch Off mode (Mode-2)

3. SIMULATION RESULT

The chosen value of the proposed circuit along with its performance is given in detail in this section. The analysis and simulation have progressed by using PSIM software. Table I contains the values of the components, which have been selected for simulation.

Table 1: Specification of the circuit parameters

Input Voltage	V_{in}	48 V
Capacitor	C_1	470 μF
Capacitors	$C_{o1} = C_{o2}$	470 μF
Inductors	$L_1 = L_2$	4.7 mH
Load Resistor	R	55 Ω
Switching Frequency	fHz	20 kHz

Table 2: Efficiency and output voltage comparison result

Converters	Boost	SEPIC	Proposed Boost-SEPIC
Efficiency	94.83%	87.64 %	98.60%
Output Voltage	96V	54 V	146 V

Table 2 reveals the outstanding performance in terms of output voltage and efficiency of the proposed design compared to conventional design. During simulation, conventional converters and the hybrid Boost-SEPIC converter operate at the same input voltage (24V) and same switching frequency (20 kHz).

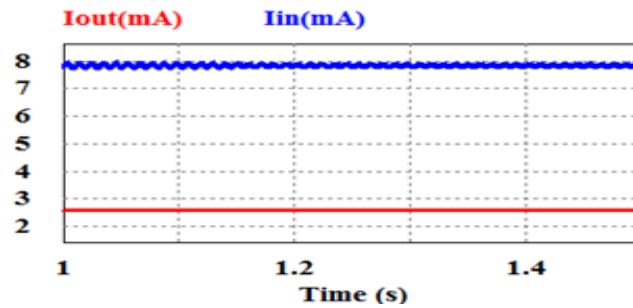

Fig. 5 Input and output current waveform of proposed system

Fig. 5 shows the input and output current. It is noticeable from the figure that the input current contains some ripple due to switching frequency and the frequency of current ripple is equivalent to the switching frequency.

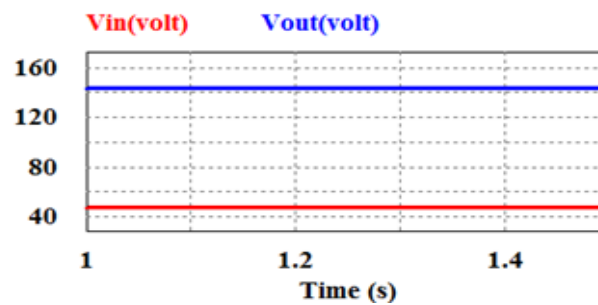

Fig. 6 Input voltage and output voltage wave diagram

Fig. 6 demonstrates the input and output voltage levels. The output voltage is almost three times greater than the input voltage. The gate pulse of the MOSFET switch for the 50% duty cycle is shown in Fig.7.

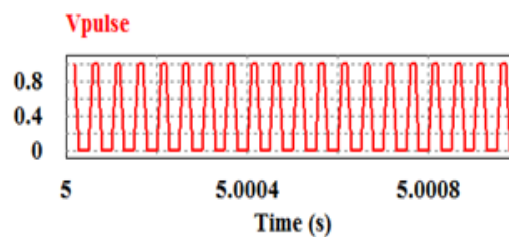

Fig.7 Switching pulse of the gate block

4. SIMULATION RESULT ANALYSIS

The Simulation results of conventional and proposed circuits are shown graphically in this section. Fig. 8(a) displays the efficiency of the conventional converter and proposed converter in the same parametric situation. It is visible from the graphical representation that the proposed circuit outperforms compared to other converter circuits.

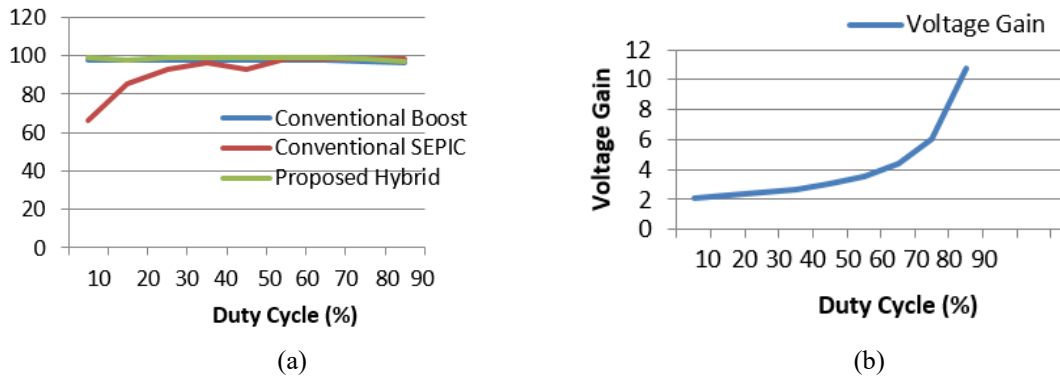

Fig. 8. Effect of duty cycle, (a) Efficiency and (b) Voltage gain

Fig. 8(b) is indicating the voltage gain of the proposed converter for different duty cycles. Voltage gain increases with increasing the duty cycle. Voltage gain reaches its peak when the duty cycle is near 90%. The proposed converter can perform efficiently for different values of loads and switching frequency which has been shown in Fig. 9(a) and Fig. 9(b) respectively.

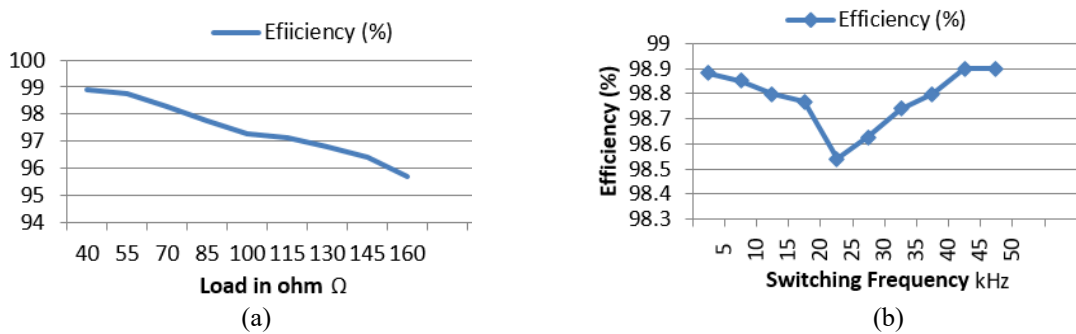

Fig. 11 Effect of efficiency of the inverter due to, (a) Load resistance and (b) Frequency

5. CONCLUSION

The analysis of the proposed hybrid Boost- SEPIC DC-DC converter depending on SMPS technology is carried out to boost the output voltage level of the photovoltaic cell. Surveying of the proposed design shows that the high voltage gain and continuous current conversion are possible to achieve without worsening the transformation efficiency. Besides that, the proposed circuit is also able to eliminate the switching and other circuit element stress. The performance of the converter has been simulated and tested under different parameters variation such as switching frequencies, duty cycle and load with the help of PSIM software. From the result and analysis, it is obvious that the recommended configuration is performing better than the existing configuration. The proposed converter demonstrated its capacity to meet solar source requirements by offering high amplitude and efficiency (98%).

REFERENCES

- [1] S. Ali et al., "Evaluating green technology strategies for the sustainable development of solar power projects: Evidence from Pakistan," *Sustain.*, vol. 13, no. 23, pp. 1–29, 2021, doi: 10.3390/su132312997.
- [2] F. Mumtaz, N. Zaihar Yahaya, S. Tanzim Meraj, B. Singh, R. Kannan, and O. Ibrahim, "Review on non-isolated DC-DC converters and their control techniques for renewable energy applications," *Ain Shams Eng. J.*, vol. 12, no. 4, pp. 3747–3763, 2021, doi: 10.1016/j.asej.2021.03.022.
- [3] A. Torkan and M. Ehsani, "A Novel Nonisolated Z-Source DC-DC Converter for Photovoltaic Applications," *IEEE Trans. Ind. Appl.*, vol. 54, no. 5, pp. 4574–4583, 2018, doi: 10.1109/TIA.2018.2833821.
- [4] S. Salehi, N. Zahedi, R. Kheirollahi, and E. Babaei, "Ultra High Step-up DC-DC Converter Based on Switched Inductor-Capacitor Cells," 2019 10th Int. Power Electron. Drive Syst. Technol. Conf. PEDSTC

- 2019, pp. 367–372, 2019, doi: 10.1109/PEDSTC.2019.8697841.
- [5] S. Poshtkouhi and O. Trescases, “Multi-input single-inductor DC-DC converter for MPPT in parallel-connected photovoltaic applications,” *Conf. Proc. - IEEE Appl. Power Electron. Conf. Expo. - APEC*, vol. 4, pp. 41–47, 2011, doi: 10.1109/APEC.2011.5744573.
- [6] K. Kanathipan, M. A. M. Cheema, and J. Lam, “Five-Level Inverter With A Combined DC Voltage Balancing and Fault-voltage Mitigation Technique for Grid-Connected PV Energy Systems,” *2021 IEEE PES Innov. Smart Grid Technol. - Asia, ISGT Asia 2021*, 2021, doi: 10.1109/ISGTASIA49270.2021.9715629.
- [7] E. Ragonese, N. Spina, A. Parisi, and G. Palmisano, “An experimental comparison of galvanically isolated dc-dc converters: Isolation technology and integration approach,” *Electron.*, vol. 10, no. 10, 2021, doi: 10.3390/electronics10101186.
- [8] O. Kircioğlu, M. Ünlü, and S. Çamur, “Modeling and analysis of DC-DC SEPIC converter with coupled inductors,” *2016 Int. Symp. Ind. Electron. INDEL 2016 - Proc.*, 2016, doi: 10.1109/INDEL.2016.7797807.
- [9] C. Muranda, E. Ozsoy, S. Padmanaban, M. S. Bhaskar, V. Fedák, and V. K. Ramachandaramurthy, “Modified SEPIC DC-to-DC boost converter with high output-gain configuration for renewable applications,” *2017 IEEE Conf. Energy Conversion, CENCON 2017*, vol. 2018-January, pp. 317–322, 2017, doi: 10.1109/CENCON.2017.8262505.
- [10] K. S. Kavın and P. Subha Karuvelam, “PV-based Grid-Interactive PMBLDC Electric Vehicle with High Gain Interleaved DC-DC SEPIC Converter,” *IETE J. Res.*, 2021, doi: 10.1080/03772063.2021.1958070.
- [11] A. Mahmood et al., “A Non-Inverting High Gain DC-DC Converter with Continuous Input Current,” *IEEE Access*, vol. 9, pp. 54710–54721, 2021, doi: 10.1109/ACCESS.2021.3070554.
- [12] R. Rahimi, S. Habibi, P. Shamsi, and M. Ferdowsi, “A Dual-Switch Coupled Inductor-Based High Step-Up DC-DC Converter for Photovoltaic-Based Renewable Energy Applications,” pp. 1–6, 2021.
- [13] L. Yang, J. Peng, F. Yang, Y. Zhang, and H. Wu, “Single-Phase High-gain Bidirectional DC/AC Converter Based on High Step-up/step-down DC/DC Converter and Dual-input DC/AC Converter,” *PEDG 2019 - 2019 IEEE 10th Int. Symp. Power Electron. Distrib. Gener. Syst.*, pp. 554–559, 2019, doi: 10.1109/PEDG.2019.8807762.
-